

Agilent Technologies E5400-Pro Series Soft Touch Connectorless Probes

User's Guide



Agilent Technologies

Notices

© Agilent Technologies, Inc. 2004-2005

No part of this manual may be reproduced in any form or by any means (including electronic storage and retrieval or translation into a foreign language) without prior agreement and written consent from Agilent Technologies, Inc. as governed by United States and international copyright laws.

Manual Part Number

E5404-97005, May 2006

Print History

E5404-97000, June 2004
E5404-97002, November 2004
E5404-97003, May 2005
E5404-97004, August 2005
E5404-97005, May 2006

Agilent Technologies, Inc.
1900 Garden of the Gods Road
Colorado Springs, CO 80907 USA

Warranty

The material contained in this document is provided “as is,” and is subject to being changed, without notice, in future editions. Further, to the maximum extent permitted by applicable law, Agilent disclaims all warranties, either express or implied, with regard to this manual and any information contained herein, including but not limited to the implied warranties of merchantability and fitness for a particular purpose. Agilent shall not be liable for errors or for incidental or consequential damages in connection with the furnishing, use, or performance of this document or of any information contained herein. Should Agilent and the user have a separate written agreement with warranty terms covering the material in this document that conflict with these terms, the warranty terms in the separate agreement shall control.

Technology Licenses

The hardware and/or software described in this document are furnished under a license and may be used or copied only in accordance with the terms of such license.

Restricted Rights Legend

If software is for use in the performance of a U.S. Government prime contract or subcontract, Software is delivered and licensed as “Commercial computer software” as defined in DFAR 252.227-7014 (June 1995), or as a “commercial item” as defined in FAR 2.101(a) or as “Restricted computer software” as defined in FAR 52.227-19 (June 1987) or any equivalent agency regulation or contract clause. Use, duplication or disclosure of Software is subject to Agilent Technologies’ standard commercial license terms, and non-DOD Departments and Agencies of the U.S. Government will receive no greater than Restricted Rights as defined in FAR 52.227-19(c)(1-2) (June

1987). U.S. Government users will receive no greater than Limited Rights as defined in FAR 52.227-14 (June 1987) or DFAR 252.227-7015 (b)(2) (November 1995), as applicable in any technical data.

Safety Notices

CAUTION

A **CAUTION** notice denotes a hazard. It calls attention to an operating procedure, practice, or the like that, if not correctly performed or adhered to, could result in damage to the product or loss of important data. Do not proceed beyond a **CAUTION** notice until the indicated conditions are fully understood and met.

WARNING

A **WARNING** notice denotes a hazard. It calls attention to an operating procedure, practice, or the like that, if not correctly performed or adhered to, could result in personal injury or death. Do not proceed beyond a **WARNING** notice until the indicated conditions are fully understood and met.

Contents

1 Overview, Installation, and Selection of Probing Options

The E5400-Pro Series Soft Touch Probes — at a Glance	8
Installation Instructions	10
Selection of Probing Options	12
Retention Modules	13
The E5402A-Pro Series Low-profile Right-angle 34-channel Single-ended Soft Touch Probe (for analyzers with 90-pin cable connectors)	14
The E5404A-Pro Series 34-channel Single-ended Soft Touch Probe (for analyzers with 40-pin cable connectors)	15
The E5405A-Pro Series 17-channel Differential Soft Touch Probe (for analyzers with 90-pin cable connectors)	16
The E5406A-Pro Series 34-channel Single-ended Soft Touch Probe (for analyzers with 90-pin cable connectors)	17
The E5386A Half-channel Adapter (for use with the 16760A logic analyzer)	18

2 Mechanical Considerations

Characteristics	20
Probe Dimensions	21
Board Layout Dimensions	25
Retention Module Dimensions	25
Footprint Dimensions	27
Pin Outs for the Probes	28
Probing with E5404A-Pro Series Probe	29

	Probing with the E5405A-Pro Series Probe	32
	Probing with the E5402A/E5406A-Pro Series Probe	34
	E5386A Half-channel Adapter Dimensions	36
	Pin out for the E5386A half-channel adapter when connected to E5405A	37
	Pin out for two E5386A half-channel adapters connected to one E5402A or E5406A	38
3	Operating the E5404A-Pro Series Probes	
	Equivalent Probe Loads	42
	Time Domain Transmission (TDT)	44
4	Operating the E5402A, E5405A and E5406A-Pro Series Probes	
	Equivalent Probe Loads	48
	Time Domain Transmission (TDT)	50
	Step Inputs	53
	Eye Opening	56
5	Circuit Board Design	
	Transmission Line Considerations	60
	Recommended Routing	61
	Data and Clock Inputs per Operating Mode	63
	Thresholds	66
	E5404A-pro series single-ended soft touch probes	66
	E5405A-pro series differential soft touch probe	66
	E5402A and E5406A-pro series single-ended soft touch probes	67
	Signal Access	67
	Labels split across probes	67
	Reordered bits	67

Half-channel 1.25 and 1.5 Gb/s modes (16760A only) 68

6 Recommended Reading

For More Information 70

MECL System Design Handbook 70

High-speed Digital Design 70

Designing High-speed Target Systems for Logic Analyzer
Probing 70



1 Overview, Installation, and Selection of Probing Options



The E5400-Pro Series Soft Touch Probes — at a Glance

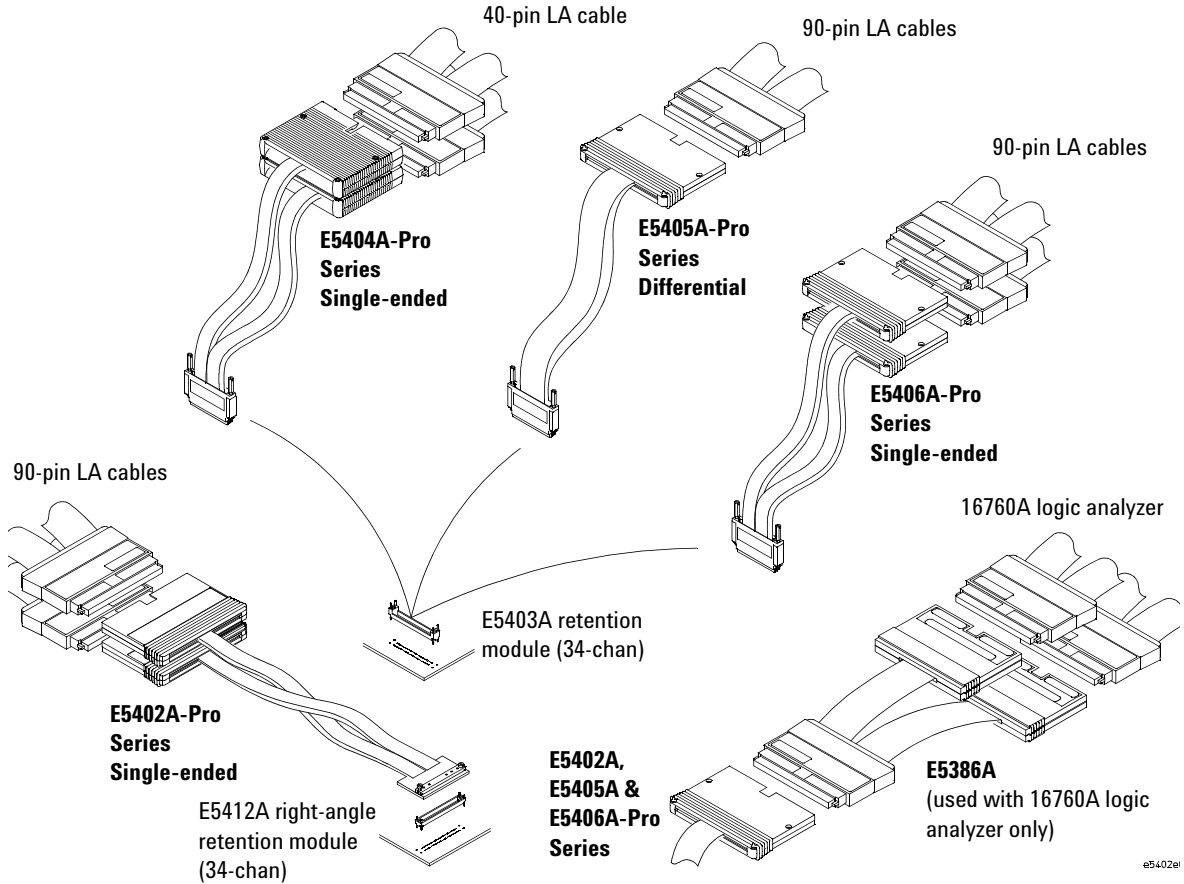

The new Agilent E5400-pro series soft touch probes are ultra-low-load connector-less probes that work with the Agilent logic analysis modules. The probes attach to the PC board using a retention module which ensures pin-to-pad alignment and holds the probe in place.

- The E5402A-pro series probe is a low-profile right-angle 34-channel single-ended connectorless soft touch probe (for analyzers with 90-pin cable connectors).
- The E5404A-pro series probe is a 34-channel single-ended connectorless soft touch probe (for analyzers with 40-pin cable connectors).
- The E5405A-pro series probe is a 17-channel differential connectorless soft touch probe (for analyzers with 90-pin cable connectors).
- The E5406A-pro series probe is a 34-channel single-ended connectorless soft touch probe (for analyzers with 90-pin cable connectors).

Use the following information to design your target system board for use with the Agilent soft touch probes.

Installation Instructions

- 1 Use the information provided in Chapter 2 to design pads on your board and holes for mounting the retention module.

The soft touch probes are attached to the PC board using a retention module which ensures pin-to-pad alignment and holds the probe in place.

- 2 Use flux as necessary to clean the board and pins before soldering the retention module to the board.
- 3 If your board has Organic Solder Preservative (OSP) finish, apply solder paste to the footprint pads prior to reflow or hand soldering.

Typically, dipped and coated finishes do not require extra solder paste.

- 4 Attach the retention module to the board from either the top or bottom of the board:

Top-side attach

Can be used with most board thicknesses.

- a Insert the retention module into the board noting the keying pin.
- b Solder alignment pins from the top ensuring that solder is added until a fillet is visible on the pin.

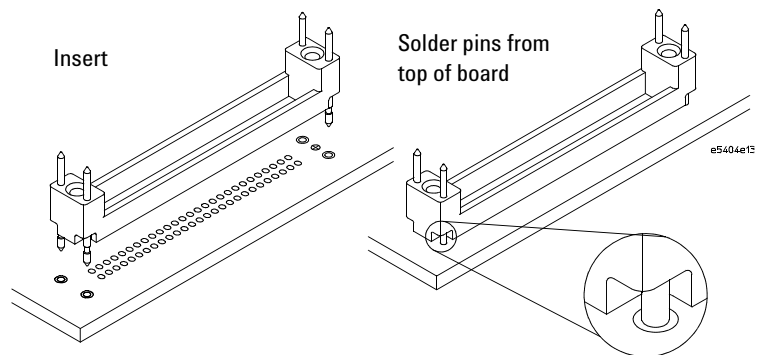

Figure 1 Solder retention module from the top.

Bottom-side attach

Can be used for board thickness of 2.54 mm (0.100 in.) or less.

- a** Insert the retention module into the board noting the keying pin.
 - b** Solder the alignment pins to the back side of the board.
- 5** Insert the probe into the retention module.

Ensure proper keying by aligning the Agilent logo on the probe with the one on the retention module and place the probe end into the retention module.

- 6** Alternate turning each screw on the probe a little until both screws are finger tight like you would attach a cable to your PC.

Selection of Probing Options

This chapter provides descriptions of the logic analyzer probes and adapters to help you select the appropriate probe for your application. The first table shows how many probes are required to provide connections to all channels of your logic analyzer module. The second table gives you the maximum state speed that is supported by the combination of a probe and your logic analyzer module.

Table 1 Number of Probes Required

Agilent Probe	Agilent Logic Analyzer Module					
	16760A	16753A, 16754A, 16755A, 16756A, 16950A	1670 Series (34ch), 1680/90 Series (34ch)	1670 Series (68ch), 1680/90 Series (68ch), 16715/16/17A, 16740/41/42A, 16750/51/52A&B, 16911A	1670 Series (102ch), 1680/90 Series (102ch), 16710/11/12A, 16910A	1670 Series (136ch), 1680/90 Series (136ch)
E5402A right-angle 34-channel single-ended soft touch probe (90-pin)	1	2	n/a	n/a	n/a	n/a
E5404A 34-channel single-ended soft touch probe (40-pin)	n/a	n/a	1	2	3	4
E5405A 17-channel differential soft touch probe (90-pin)	2	4	n/a	n/a	n/a	n/a
E5406A 34-channel single-ended soft touch probe (90-pin)	1	2	n/a	n/a	n/a	n/a

Table 2 Maximum State Speed Supported

Probe	Logic Analyzer Module			
	16760A	16753A, 16754A, 16755A, 16756A 16950A	1670 Series 1680/90 Series, 16710/11/12A, 16715/16/17A, 16740/41/4A, 16750/51/52A&B	16910A/16911A
E5402A right-angle 34-channel single-ended soft touch probe	1.5 Gb/s	800 Mb/s	n/a	n/a
E5404A 34-channel single-ended soft touch probe	n/a	n/a	400 Mb/s	500 Mb/s
E5405A 17-channel differential soft touch probe	1.5 Gb/s	800 Mb/s	n/a	n/a
E5406A 34-channel single-ended soft touch probe	1.5 Gb/s	800 Mb/s	n/a	n/a

Retention Modules

A retention module ensures pin-to-pad alignment and holds the probe in place. A kit of five retention modules is supplied with each probe. Additional kits (of 5) can be ordered from Agilent Technologies at <http://www.agilent.com/find/softtouch/>. If more than 5 retention modules are needed, please contact Precision Interconnect at 10025 SW Freeman Court, Wilsonville, OR 97070, <http://www.precisionint.com/>, 1-503-685-9300.

Table 3 Ordering retention modules

Probe	Agilent Model Number (kit of 5)	Precision Interconnect Part Number (for volumes greater than 5)
E5402A right-angle 34-channel single-ended soft touch probe	E5412A	600-0182-01
E5404A 34-channel single-ended soft touch probe	E5403A	600-0153-01
E5405A 17-channel differential soft touch probe	E5403A	600-0153-01
E5406A 34-channel single-ended soft touch probe	E5403A	600-0153-01

The E5402A-Pro Series Low-profile Right-angle 34-channel Single-ended Soft Touch Probe (for analyzers with 90-pin cable connectors)

The Agilent E5402A-pro series probe is a 34-channel, single-ended, soft touch probe compatible with the Agilent logic analysis modules listed in [Table 1](#) on page 12. It is capable of capturing data up to the rated maximum state (synchronous) analysis clock rates of all the supported analyzers, with signal amplitudes as small as 250 mV peak-to-peak. A retention module must be installed on the target system board to attach the probe to the board. There is a key on the retention module that indicates the egress of the cable when the probe is attached.

A kit of five retention modules are supplied with each probe. Refer to [“Ordering retention modules”](#) on page 13 for information on ordering more.

See [“Mechanical Considerations”](#) on page 19 for information on designing your target system board.

E5402A-pro series low-profile right-angle 34-channel single-ended soft touch probe

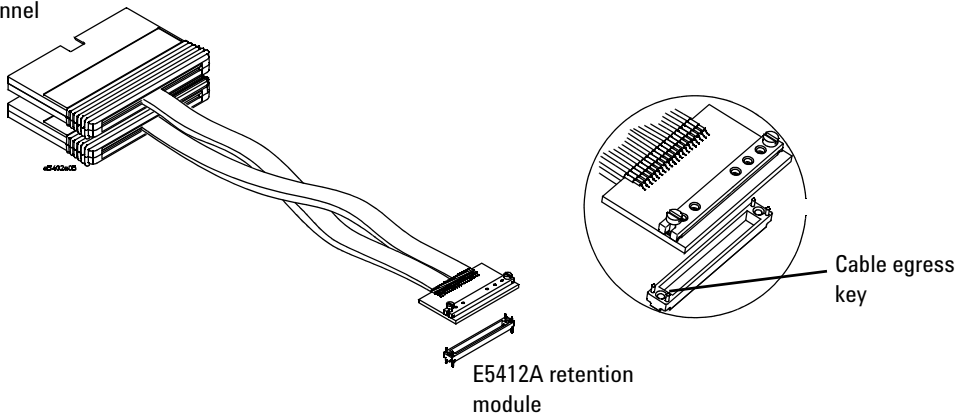

Figure 2 E5402A-pro series right-angle single-ended soft touch probe and E5412A retention module

The E5404A-Pro Series 34-channel Single-ended Soft Touch Probe (for analyzers with 40-pin cable connectors)

The Agilent E5404A-pro series probe is a 34-channel, single-ended, soft touch probe compatible with the Agilent logic analysis modules listed in [Table 1](#) on page 12. It is capable of capturing data up to the rated maximum state (synchronous) analysis clock rates of all the supported analyzers, with signal amplitudes as small as 500 mV peak-to-peak. A retention module must be installed on the target system board to attach the probe to the board.

A kit of five retention modules are supplied with each probe. Refer to [“Ordering retention modules”](#) on page 13 for information on ordering more.

See [“Mechanical Considerations”](#) on page 19 for information on designing your target system board.

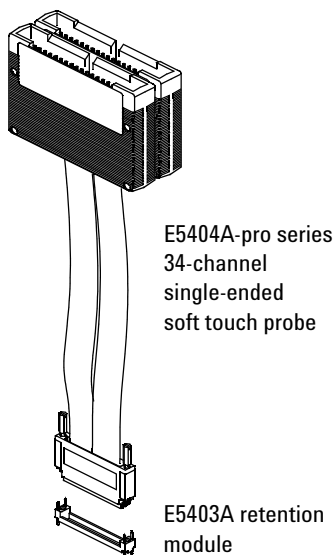

Figure 3 E5404A-pro series single-ended soft touch probe and E5403A retention module

The E5405A-Pro Series 17-channel Differential Soft Touch Probe

(for analyzers with 90-pin cable connectors)

The Agilent E5405A-pro series probe is a 17-channel, single-ended, soft touch probe compatible with the Agilent logic analysis modules listed in [Table 1](#) on page 12. It is capable of capturing data up to the rated maximum state (synchronous) analysis clock rates of all the supported analyzers, with differential signal amplitudes as small as 200 mV peak-to-peak (100 mV peak-to-peak on both positive and negative inputs). A retention module must be installed on the target system board to attach the probe to the board.

A kit of five retention modules are supplied with each probe. Refer to [“Ordering retention modules”](#) on page 13 for information on ordering more.

See [“Mechanical Considerations”](#) on page 19 for information on designing your target system board.

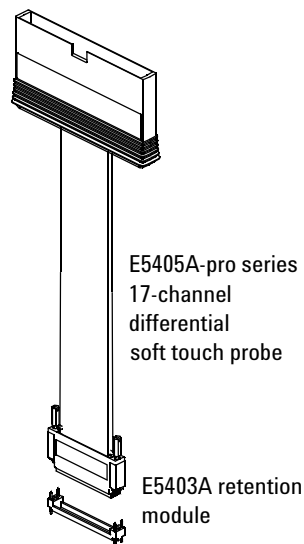

Differential Input Amplitude Definition

For differential signals, the difference voltage $V_{max} - V_{min}$ must be greater than or equal to 200 mV p-p

Figure 4 E5405A-pro series differential soft touch probe and E5403A retention module

The E5406A-Pro Series 34-channel Single-ended Soft Touch Probe (for analyzers with 90-pin cable connectors)

The Agilent E5406A-pro series probe is a 34-channel, single-ended, soft touch probe compatible with the Agilent logic analysis modules listed in [Table 1](#) on page 12. It is capable of capturing data up to the rated maximum state (synchronous) analysis clock rates of all the supported analyzers, with signal amplitudes as small as 250 mV peak-to-peak. A retention module must be installed on the target system board to attach the probe to the board.

A kit of five retention modules are supplied with each probe. Refer to [“Ordering retention modules”](#) on page 13 for information on ordering more.

See [“Mechanical Considerations”](#) on page 19 for information on designing your target system board.

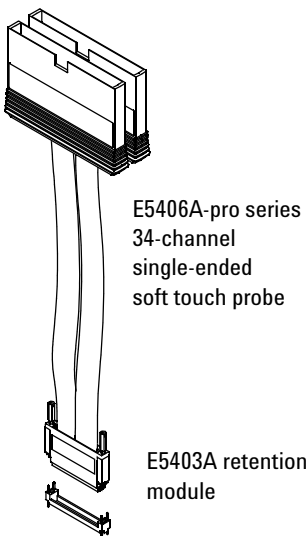
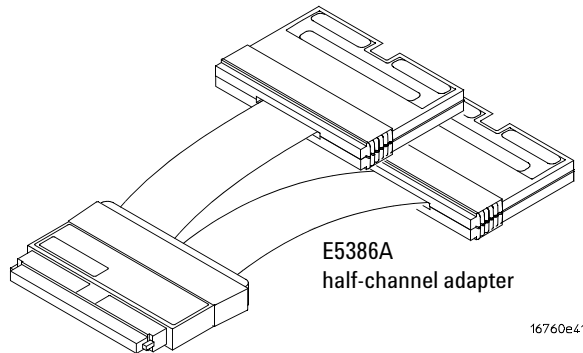

Figure 5 E5406A-pro series single-ended soft touch probe and E5403A retention module

The E5386A Half-channel Adapter (for use with the 16760A logic analyzer)

The E5386A Half-channel Adapter is intended to be used with the Agilent 16760A logic analyzer in half-channel state mode and supports the E5402A, E5405A and E5406A probes.



The E5386A Half-channel Adapter has its own ID code. When using the adapter, the 16760A logic analyzer recognizes its code rather than that of the probe which is attached to the target. Therefore, the user interface format menu doesn't automatically set thresholds to the right values. You need to go into the threshold menu and select (differential, custom, or standard settings).

When using the adapter in half-channel state mode:

- Clock-bits are not available in half-channel state mode (although JCLK on the master is still used).
- Be sure to connect Master pod 1 of the logic analyzer to the upper bits, 8-15 + clk, on the half-channel adapter. This is necessary to connect the clock in the system under test to the logic analyzer system clock.
- Using the E5386A does not reduce the performance of the 16760A logic analyzer and the soft touch probes.

If the E5386A is used in full-channel state mode, the thresholds on the unused (odd) bits are floating. This could result in spurious activity indicators in the format menu.



2 Mechanical Considerations

Use the following mechanical information to design your target system board.



Characteristics

Electrical considerations such as equivalent probe loads, input impedance, and time domain transmission are shown in chapters 3 and 4 of this manual. Other characteristics are dependant on the logic analyzer module you are using.

Probe Dimensions

The following figures show the dimensions of the Agilent E5400-pro series soft touch probes.

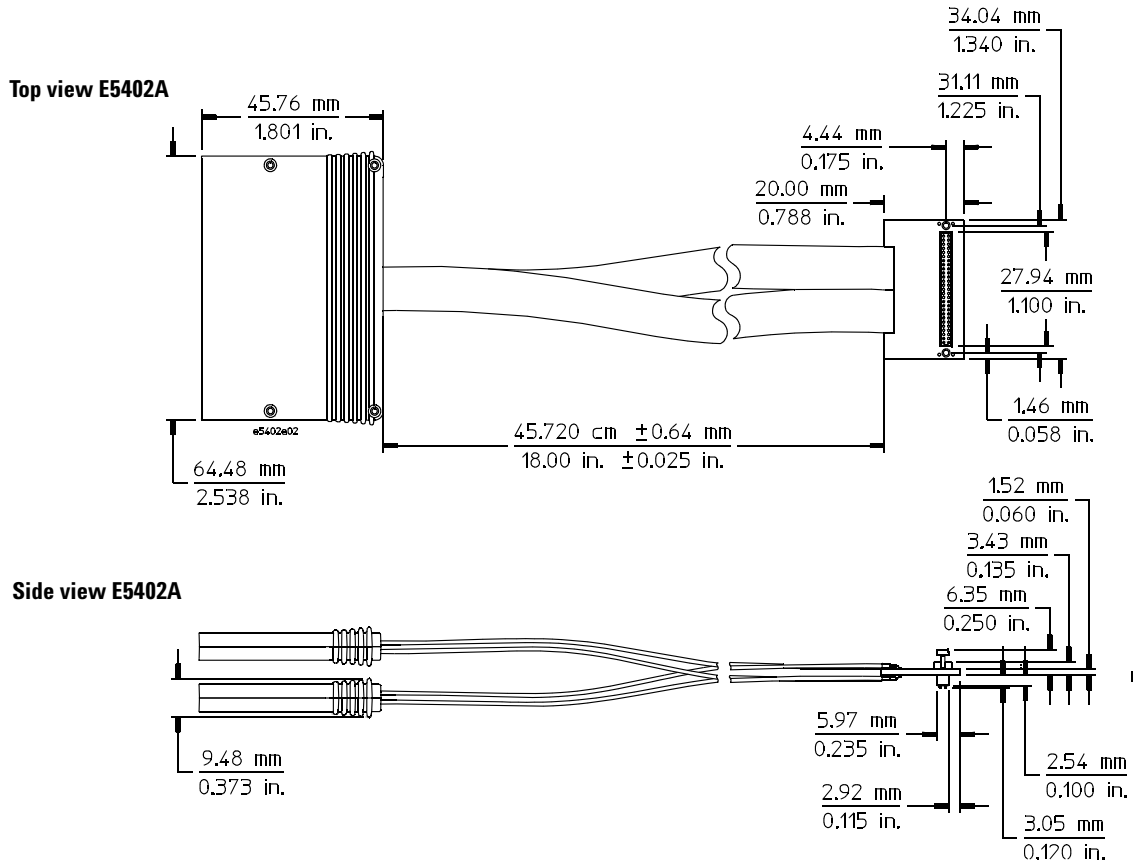

Figure 6 E5402A probe dimensions

2 Mechanical Considerations

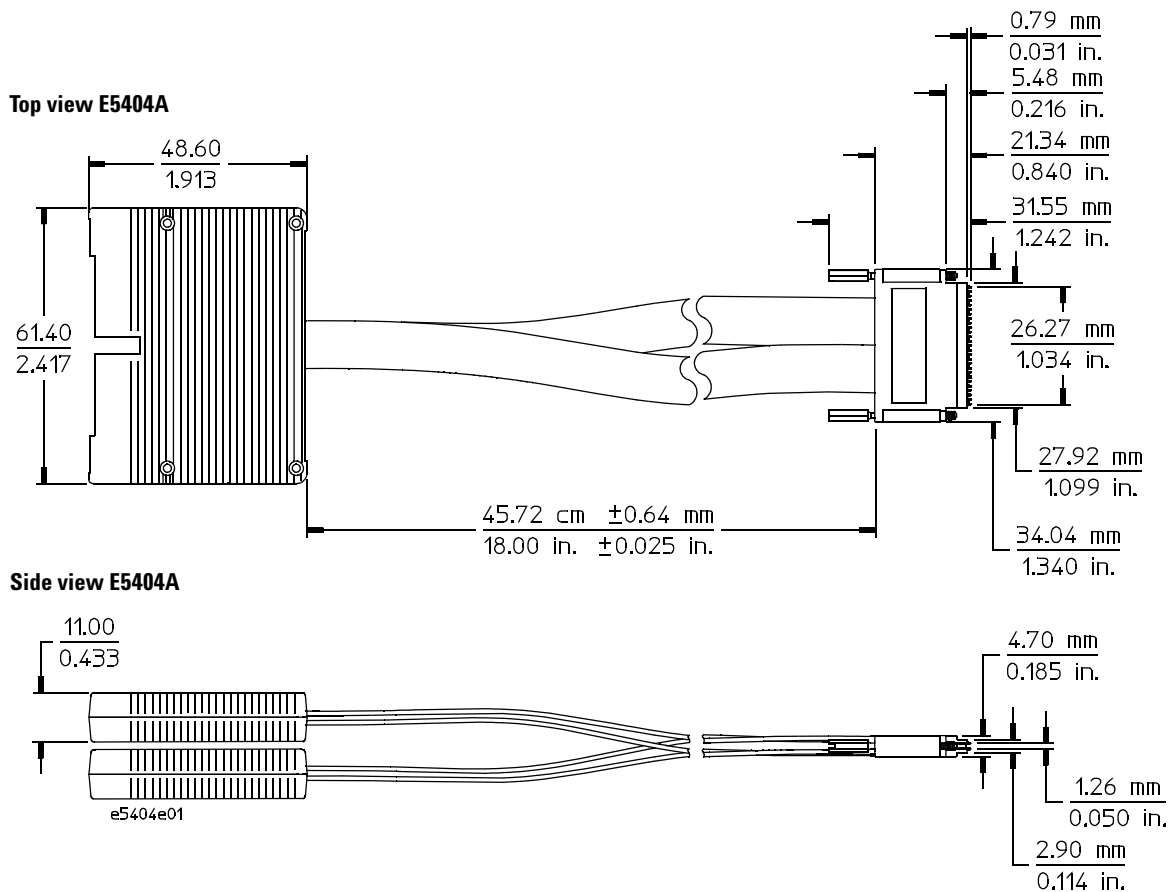

Figure 7 E5404A probe dimensions

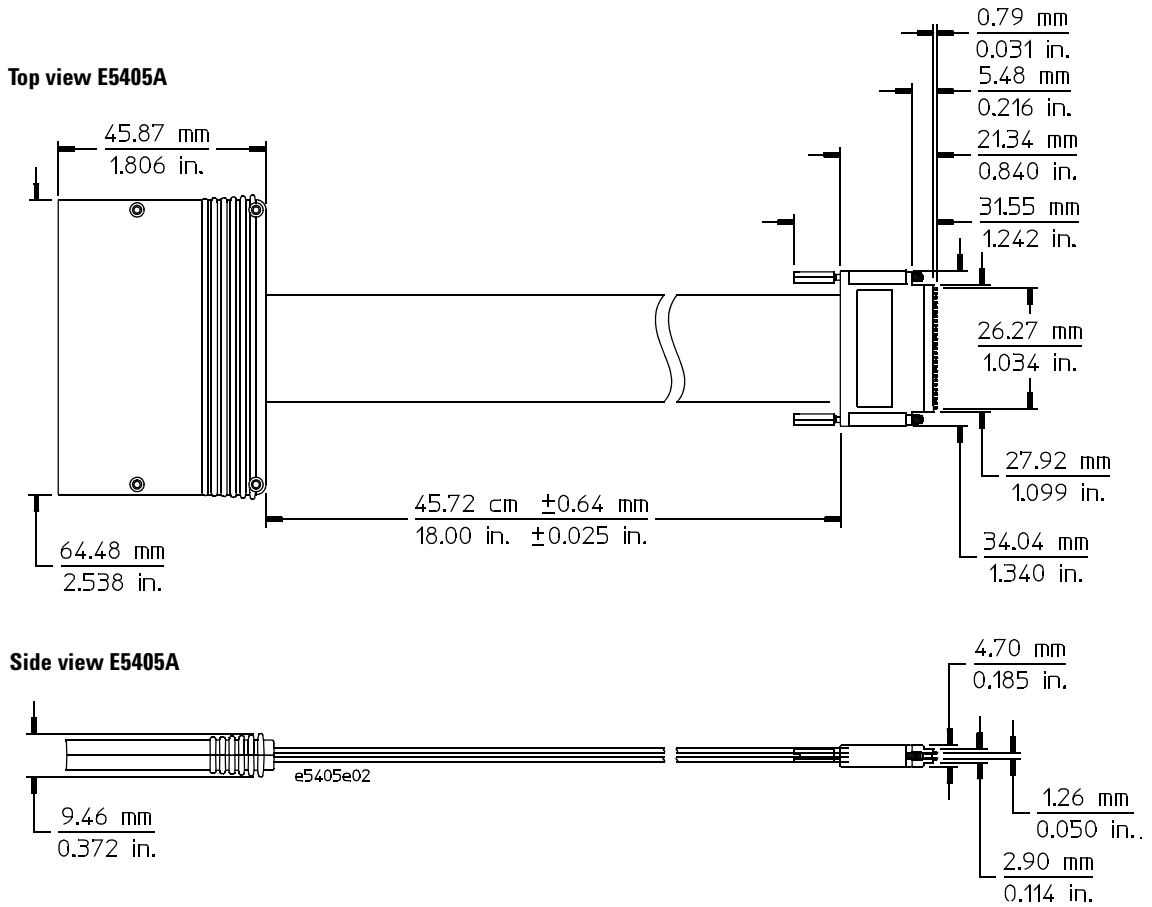

Figure 8 E5405A probe dimensions

2 Mechanical Considerations

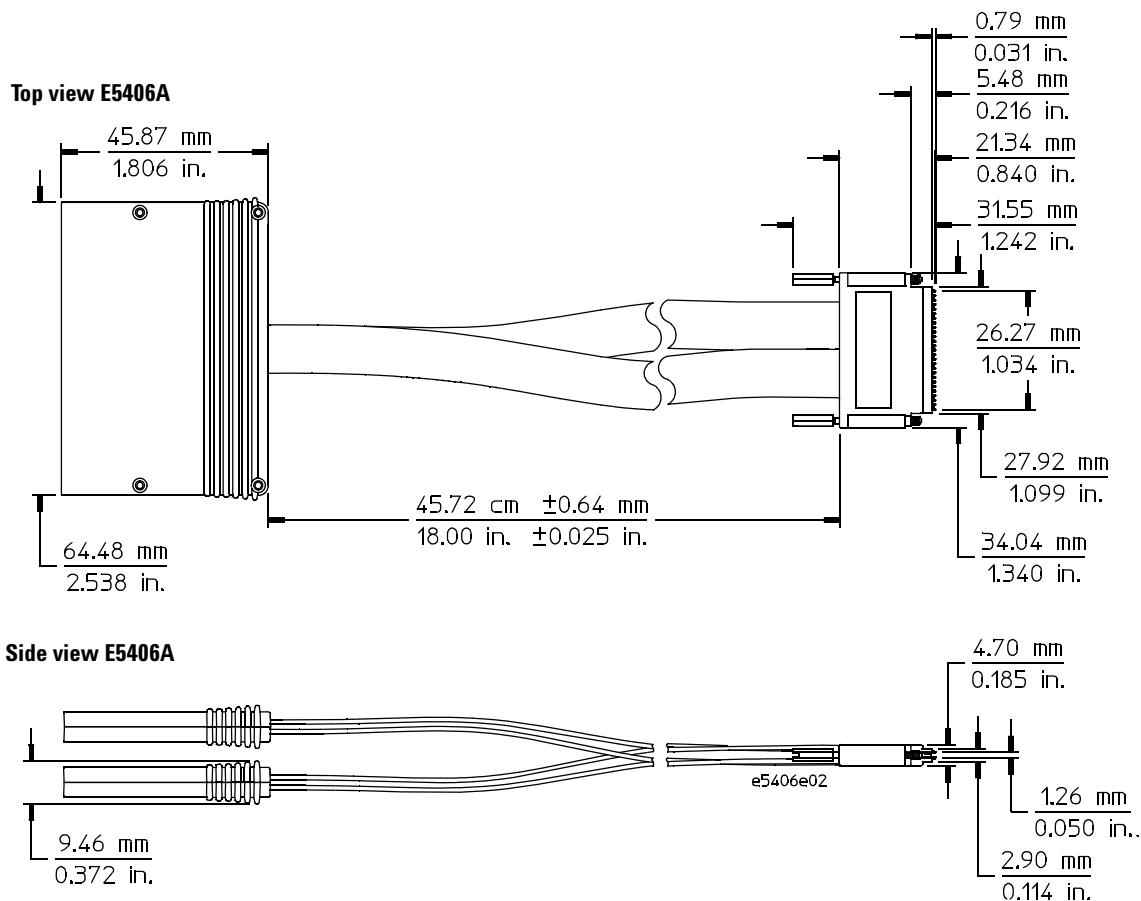

Figure 9 E5406A probe dimensions

Board Layout Dimensions

Use the following dimensions to layout your PC board pads and holes for use with the soft touch probes.

Retention Module Dimensions

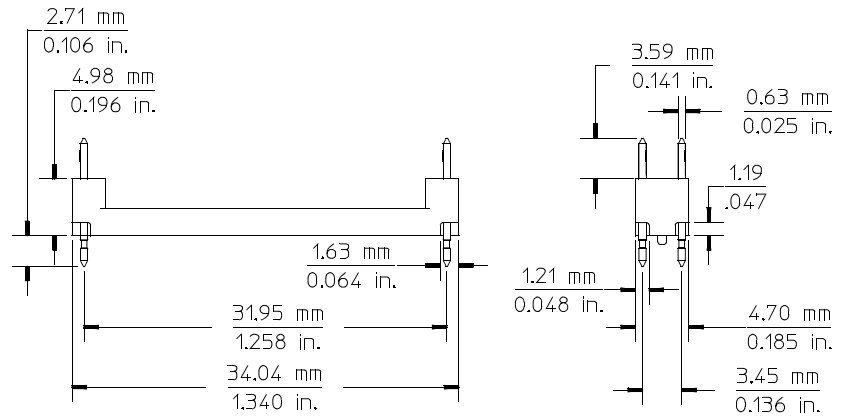

Figure 10 E5403A retention module dimensions

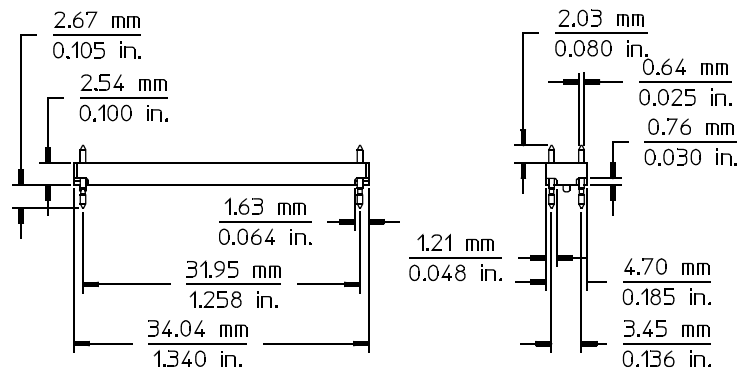

Figure 11 E5412A retention module dimensions

2 Mechanical Considerations

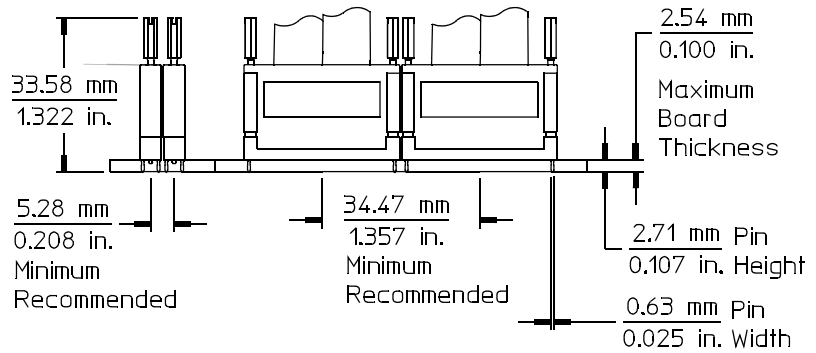
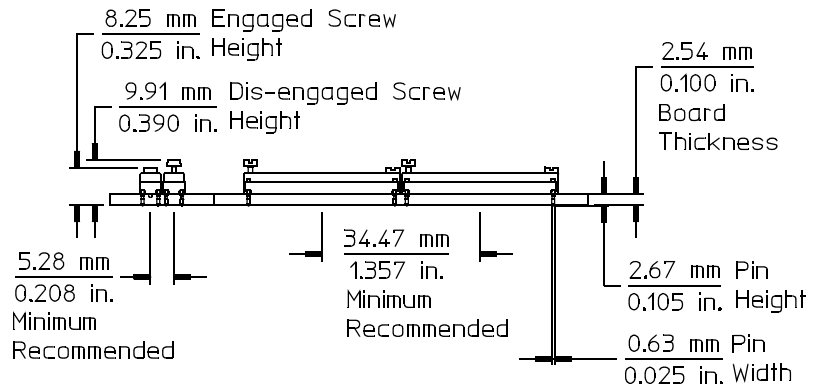

Figure 12 E5403A side-by-side dimensions



Optimal board thickness for this top-side mount retention module is shown above. Retention modules can be hand soldered into thicker boards, but will not form a bottom-side solder fillet.

Figure 13 E5412A side-by-side dimensions

Footprint Dimensions

The retention module alignment is symmetrical around the pad footprint.

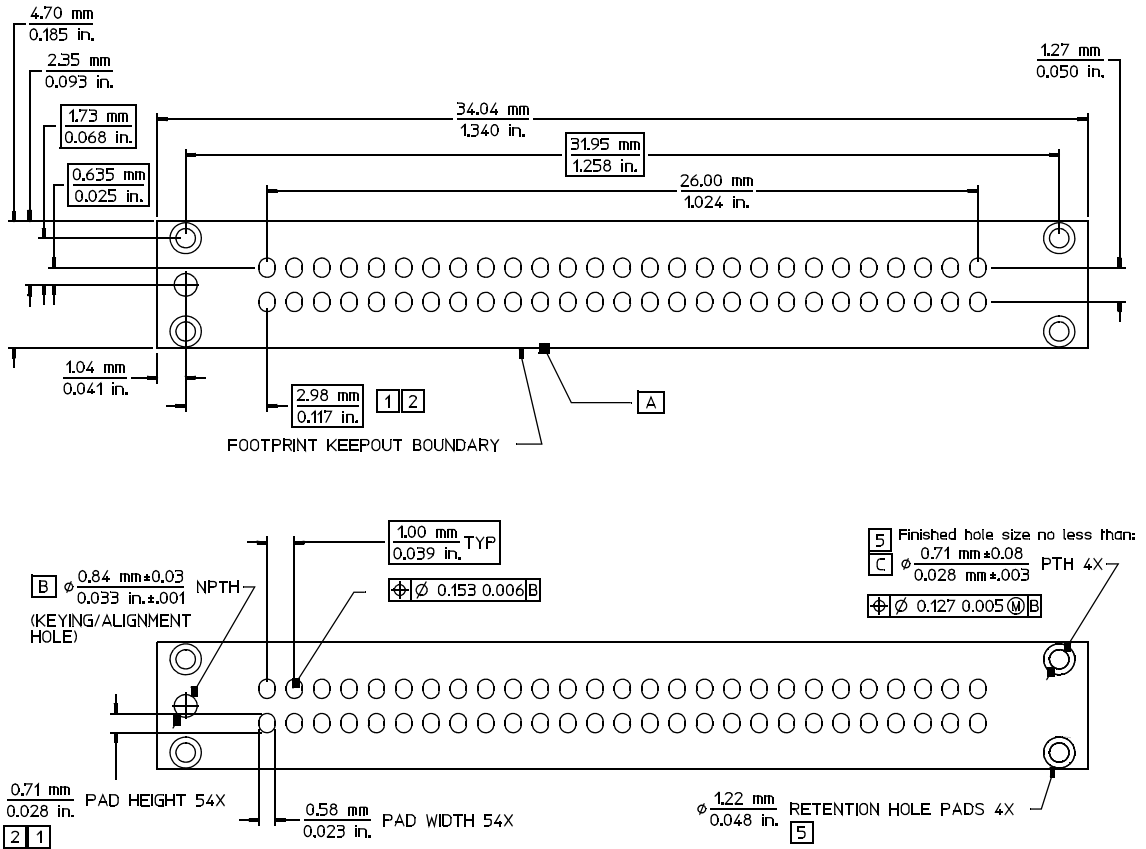
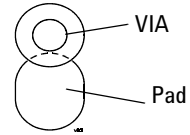

Figure 14 Top view footprint dimensions (drawing notes next page).

Drawing notes:

- 1 Maintain a solder mask web between pads when traces are routed between the pads on the same layer. The solder mask may not encroach onto the pads within the pad dimension shown.
- 2 VIAs not allowed on these pads. VIA edges may be tangent to pad edges as long as a solder mask web between VIAs and pads is maintained.
- 3 Surface finishes on pads should be HASL immersion silver, or gold over nickel.
- 4 This footprint is compatible with retention module Agilent model number E5403A.
- 5 Plated through hole should not be tied to ground plane for thermal relief.



Pin Outs for the Probes

NOTE

If you will be using the soft touch probes with a 16900-series logic analyzer running V2.5 or higher, probe types can be defined in XML configuration files. To get the latest Probes.xml file, go to www.agilent.com/find/probexml? Install the file in c:\Program Files\Agilent Technologies\AddIns\Agilent\. Refer to the logic analyzer on-line help for more information.

Probing with E5404A-Pro Series Probe

The following footprint provides pin out and pad numbers for the E5404A single-ended probe for use with 40-pin logic analyzers.

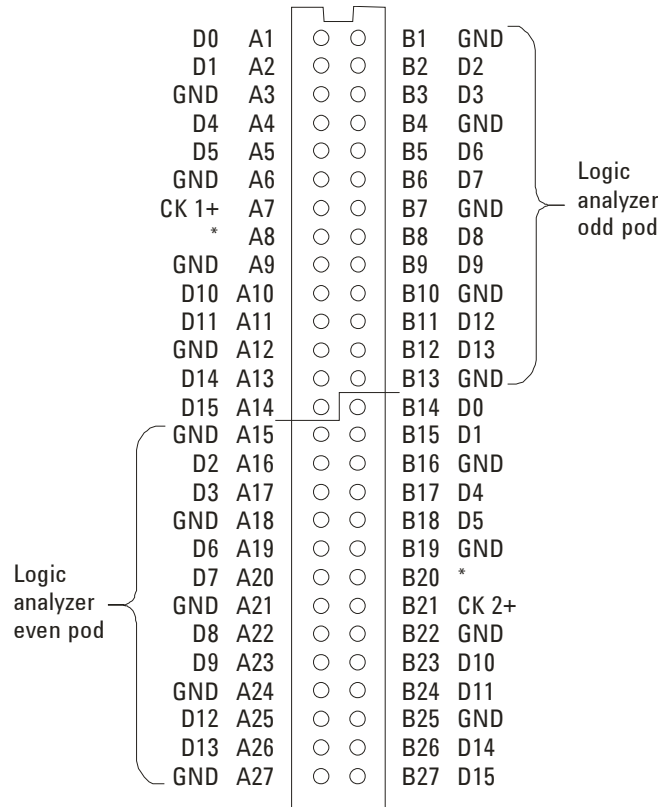

Figure 15 Pad numbers for E5404A-pro series.

* If you only plan to use the E5404A 40-pin probe with single-ended clocking to probe the following footprint, then A8 and B20 are unused. They can be grounded, not connected, left floating, or driven. These pads are not probed with the E5404A probe.

2 Mechanical Considerations

If you ever plan on upgrading from a 40-pin to a 90-pin logic analyzer to take advantage of higher state speed and differential probing on the clock channel, some steps should be taken so that the original footprint will work for both the E5404A and the E5406A probes.

- If you are driving only single-ended clocks into A7 (CK1+) and B21 (CK2+), then you should ground A8 and B20. A8 and B20 are where CK1- and CK2- are driven in the E5406A probe. Grounding these pads will allow the user-defined threshold in the analyzer to be used as in normal single-ended operation.
- If you are using differential clocks, route the Odd pod clock such that the positive side of the pair goes to A7 (CK1+) and the negative side of the pair goes to A8 (CK1-). Similarly, route the Even pod clock such that the positive side of the pair goes to B21 (CK2+) and the negative side of the pair goes to B20 (CK2-). When using the E5404A probe, A8 and B20 are unused. However, when using the E5406A probe, A8 and B20 are where the probe connects to the negative sides of the clocks' differential pair.

E5404A 34-channel Single-ended Probe		Logic Analyzer	
Signal Name	Pad #	Channel	Pod
D0	A1	→ 0	Whichever pod is connected to "Odd" on the E5404A probe
D1	A2	→ 1	
Ground	A3		
D4	A4	→ 4	
D5	A5	→ 5	
Ground	A6		
Clock 1+	A7	→ Clock	
GND/NC/ Clock 1-	A8	→ See * pg 25	
Ground	A9		
D10	A10	→ 10	
D11	A11	→ 11	
Ground	A12		
D14	A13	→ 14	
D15	A14	→ 15	
Ground	A15		
D2	A16	→ 2	
D3	A17	→ 3	
Ground	A18		
D6	A19	→ 6	
D7	A20	→ 7	
Ground	A21		
D8	A22	→ 8	
D9	A23	→ 9	
Ground	A24		
D12	A25	→ 12	
D13	A26	→ 13	
Ground	A27		

E5404A 34-channel Single-ended Probe		Logic Analyzer	
Signal Name	Pad #	Channel	Pod
Ground	B1		Whichever pod is connected to "Odd" on the E5404A probe
D2	B2	→ 2	
D3	B3	→ 3	
Ground	B4		
D6	B5	→ 6	
D7	B6	→ 7	
Ground	B7		
D8	B8	→ 8	
D9	B9	→ 9	
Ground	B10		
D12	B11	→ 12	
D13	B12	→ 13	
Ground	B13		
D0	B14	→ 0	
D1	B15	→ 1	
Ground	B16		
D4	B17	→ 4	
D5	B18	→ 5	
Ground	B19		
Ground/NC /Clock 2-	B20	→ See * pg 25	
Clock 2+	B21	→ Clock	
Ground	B22		
D10	B23	→ 10	
D11	B24	→ 11	
Ground	B25		
D14	B26	→ 14	
D15	B27	→ 15	

Probing with the E5405A-Pro Series Probe

The following footprint provides pin out and pad numbers for the E5405A differential probe for use with 90-pin logic analyzers.

D0+	A1	○	○	B1	GND
D0-	A2	○	○	B2	D1-
GND	A3	○	○	B3	D1+
D2+	A4	○	○	B4	GND
D2-	A5	○	○	B5	D3-
GND	A6	○	○	B6	D3+
D4+	A7	○	○	B7	GND
D4-	A8	○	○	B8	D5-
GND	A9	○	○	B9	D5+
D6+	A10	○	○	B10	GND
D6-	A11	○	○	B11	D7-
GND	A12	○	○	B12	D7+
NC	A13	○	○	B13	GND
NC	A14	○	○	B14	CLK-
GND	A15	○	○	B15	CLK+
D8+	A16	○	○	B16	GND
D8-	A17	○	○	B17	D9-
GND	A18	○	○	B18	D9+
D10+	A19	○	○	B19	GND
D10-	A20	○	○	B20	D11-
GND	A21	○	○	B21	D11+
D12+	A22	○	○	B22	GND
D12-	A23	○	○	B23	D13-
GND	A24	○	○	B24	D13+
D14+	A25	○	○	B25	GND
D14-	A26	○	○	B26	D15-
GND	A27	○	○	B27	D15+

Figure 16 Pad numbers for E5405A-pro series.

E5405A Differential Probe		Logic Analyzer		
Signal Name	Pad#		Channel	Pod
D0 (+)	A1	→	0	Whichever pod is plugged into the E5405A probe
D0 (-)	A2			
Ground	A3			
D2 (+)	A4	→	2	
D2 (-)	A5			
Ground	A6			
D4 (+)	A7	→	4	
D4 (-)	A8			
Ground	A9			
D6 (+)	A10	→	6	
D6 (-)	A11			
Ground	A12			
NC	A13			
NC	A14			
GND	A15			
D8 (+)	A16	→	8	
D8 (-)	A17			
Ground	A18			
D10 (+)	A19	→	10	
D10 (-)	A20			
Ground	A21			
D12 (+)	A22	→	12	
D12 (-)	A23			
Ground	A24			
D14 (+)	A25	→	14	
D14 (-)	A26			
Ground	A27			

E5405A Differential Probe		Logic Analyzer		
Signal Name	Pad#		Channel	Pod
Ground	B1			Whichever pod is plugged into the E5405A probe
D1 (-)	B2			
D1 (+)	B3	→	1	
Ground	B4			
D3 (-)	B5			
D3 (+)	B6	→	3	
Ground	B7			
D5 (-)	B8			
D5 (+)	B9	→	5	
Ground	B10			
D7 (-)	B11			
D7 (+)	B12	→	7	
Ground	B13			
Clock -	B14			
Clock +	B15	→	Clock	
Ground	B16			
D9 (-)	B17			
D9 (+)	B18	→	9	
Ground	B19			
D11 (-)	B20			
D11 (+)	B21	→	11	
Ground	B22			
D13 (-)	B23			
D13 (+)	B24	→	13	
Ground	B25			
D15 (-)	B26			
D15 (+)	B27	→	15	

Probing with the E5402A/E5406A-Pro Series Probe

The following footprint provides pin out and pad numbers for the E5402A/E5406A single-ended probe for use with 90-pin logic analyzers.

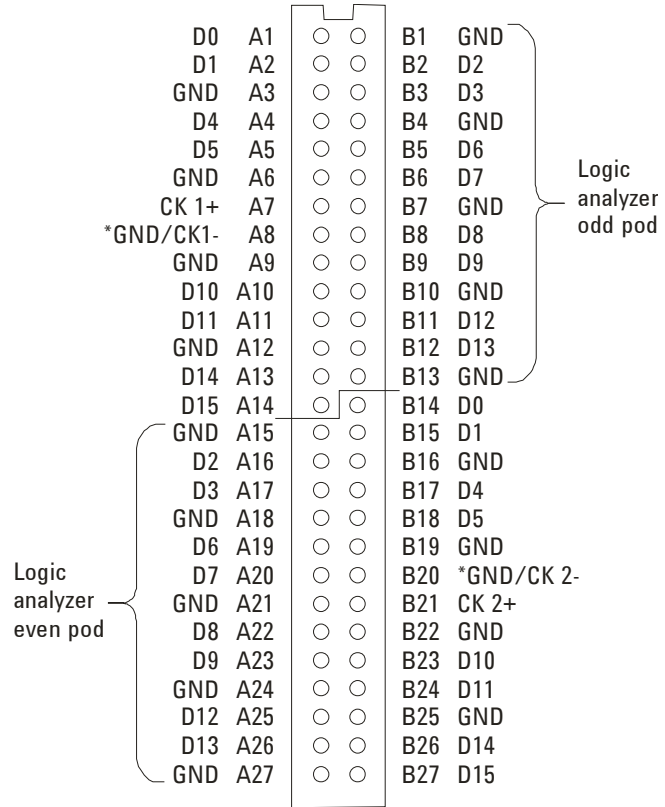

Figure 17 Pad numbers for E5402/E5406A-pro series

E5402A/E5406A 34-channel Single-ended Probe		Logic Analyzer		
Signal Name	Pad #	Channel	Pod	
D0	A1	→ 0	Whichever pod is connected to "Odd" on the 5402A/E5406A probe	
D1	A2	→ 1		
Ground	A3			
D4	A4	→ 4		
D5	A5	→ 5		
Ground	A6			
Clock 1+	A7	→ Clock		
GND/ Clock 1-	A8	→ Clock		
Ground	A9			
D10	A10	→ 10		
D11	A11	→ 11		
Ground	A12			
D14	A13	→ 14		
D15	A14	→ 15		
Ground	A15			Whichever pod is connected to "Even" on the E5402A/E5406A probe
D2	A16	→ 2		
D3	A17	→ 3		
Ground	A18			
D6	A19	→ 6		
D7	A20	→ 7		
Ground	A21			
D8	A22	→ 8		
D9	A23	→ 9		
Ground	A24			
D12	A25	→ 12		
D13	A26	→ 13		
Ground	A27			

E5402A/E5406A 34-channel Single-ended Probe		Logic Analyzer		
Signal Name	Pad #	Channel	Pod	
Ground	B1		Whichever pod is connected to "Odd" on the E5402/E5406A probe	
D2	B2	→ 2		
D3	B3	→ 3		
Ground	B4			
D6	B5	→ 6		
D7	B6	→ 7		
Ground	B7			
D8	B8	→ 8		
D9	B9	→ 9		
Ground	B10			
D12	B11	→ 12		
D13	B12	→ 13		
Ground	B13			
D0	B14	→ 0	Whichever pod is connected to "Even" on the E5402A/E5406A probe	
D1	B15	→ 1		
Ground	B16			
D4	B17	→ 4		
D5	B18	→ 5		
Ground	B19			
Ground/ Clock 2-	B20	→ Clock		
Clock 2+	B21	→ Clock		
Ground	B22			
D10	B23	→ 10		
D11	B24	→ 11		
Ground	B25			
D14	B26	→ 14		
D15	B27	→ 15		

E5386A Half-channel Adapter Dimensions

The E5386A half-channel adapter works with the 16760A logic analyzer and the soft touch probes.

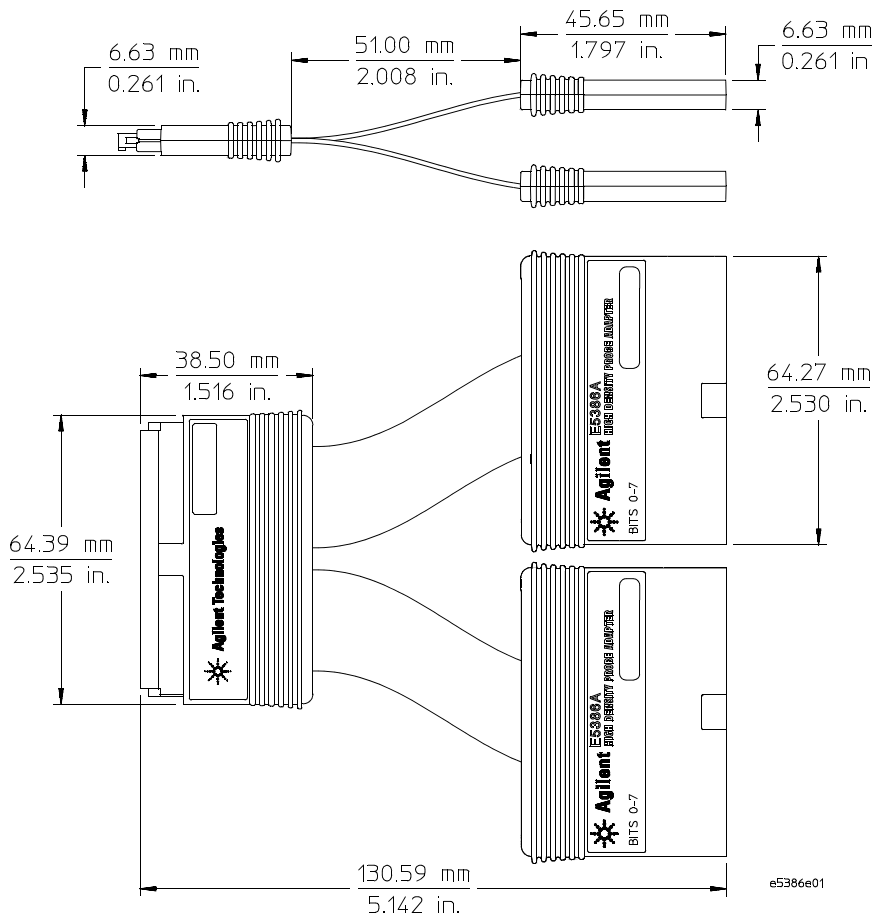

Figure 18 E5386A dimensions

Pin out for the E5386A half-channel adapter when connected to E5405A

When used with the E5405A-pro series differential soft touch probe, you need only one half-channel adapter. The table below shows the pin assignments.

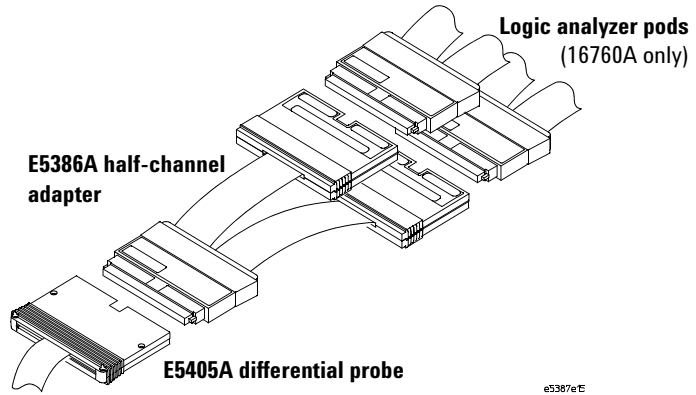

Figure 19 Half-channel adapter with E5405A-pro series

Table 4 Pin-out table for E5386A connected to an E5405A

E5405A Differential Probe				Logic Analyzer	
Negative Signals		Positive Signals		Channel	Pod
Signal Name	Pin#	Signal Name	Pin#		
D0(-)	A2	D0(+)	A1	→ 0	Whichever pod is plugged into bits 0-7 ↓
D1(-)	B2	D1(+)	B3	→ 2	
D2(-)	A5	D2(+)	A4	→ 4	
D3(-)	B5	D3(+)	B6	→ 6	
D4(-)	A8	D4(+)	A7	→ 8	
D5(-)	B8	D5(+)	B9	→ 10	
D6(-)	A11	D6(+)	A10	→ 12	
D7(-)	B11	D7(+)	B12	→ 14	

2 Mechanical Considerations

E5405A Differential Probe				Logic Analyzer	
Negative Signals		Positive Signals		Channel	Pod
Signal Name	Pin#	Signal Name	Pin#		
D8(-)	A17	D8(+)	A16	→ 0	Whichever pod is plugged into bits 8-15 ↓
D9(-)	B17	D9(+)	B18	→ 2	
D10(-)	A20	D10(+)	A19	→ 4	
D011(-)	B20	D11(+)	B21	→ 6	
D12(-)	A23	D12(+)	A22	→ 8	
D13(-)	B23	D13(+)	B24	→ 10	
D14(-)	A26	D14(+)	A25	→ 12	
D15(-)	B26	D15(+)	B27	→ 14	
D16(-)/Clk(-)	B14	D16(+)/Clk(+)	B15	→ Clock	

Pin out for two E5386A half-channel adapters connected to one E5402A or E5406A

When used with the E5402A/E5406A-pro series single-ended soft touch probe, you need two half-channel adapters, one adapter for Odd data and one for Even data. The table below shows the pin assignments.

The E5386A that is connected to the end of the E5402A/E5406A labeled 'odd' becomes the 'odd' E5386A adapter.

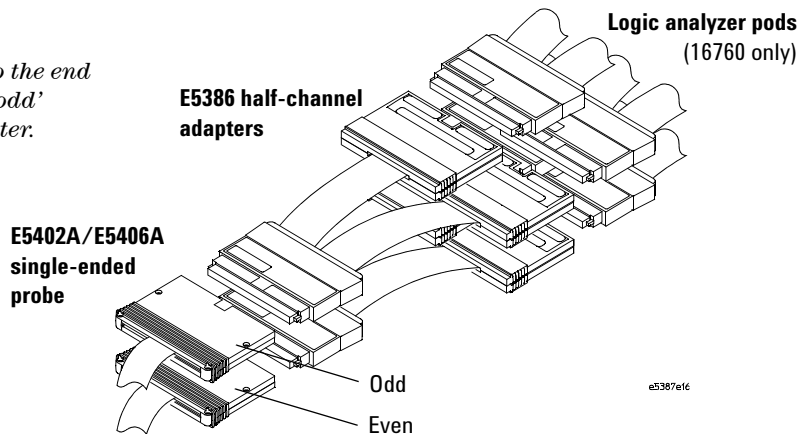
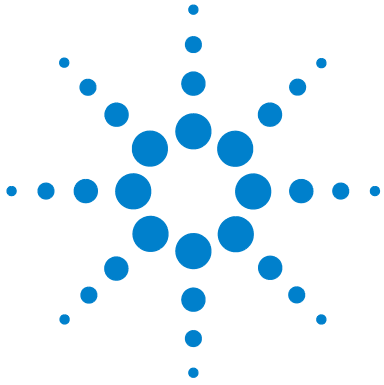

Figure 20 Two half-channel adapters with E5402A/E5406A-pro series

Table 5 Pin-out table for two E5386A adapters connected to an E5402A or E5406A

E5386A Adapter Odd					E5386A Adapter Even				
E5402A/E5406A 34-channel Single-ended Probe		Logic Analyzer			E5402A/E5406A 34-channel Single-ended Probe		Logic Analyzer		
Signal Name	Pin #	Channel	Pod		Signal Name	Pin #	Channel	Pod	
D0	A1	→ 0	Whichever pod is connected to bits 0-7 on the odd E5386A		D0	B14	→ 0	Whichever pod is connected to bits 0-7 on the even E5386A	
D1	A2	→ 2			D1	B15	→ 2		
D2	B2	→ 4			D2	A16	→ 4		
D3	B3	→ 6			D3	A17	→ 6		
D4	A4	→ 8			D4	B17	→ 8		
D5	A5	→ 10			D5	B18	→ 10		
D6	B5	→ 12			D6	A19	→ 12		
D7	B6	→ 14			D7	A20	→ 14		
D8	B8	→ 0	Whichever pod is connected to bits 8-15 on the odd E5386A		D8	A22	→ 0	Whichever pod is connected to bits 8-15 on the even E5386A	
D9	B9	→ 2			D9	A23	→ 2		
D10	A10	→ 4			D10	B23	→ 4		
D11	A11	→ 6			D11	B24	→ 6		
D12	B11	→ 8			D12	A25	→ 8		
D13	B12	→ 10			D13	A26	→ 10		
D14	A13	→ 12			D14	B26	→ 12		
D15	A14	→ 14			D15	B27	→ 14		
D16(+)/Clk(+)	A7	→ Clock(+)			D16(+)/Clk(+)	B21	→ Clock(+)		
D16(-)/Clk(-)	A8	→ Clock(-)			D16(-)/Clk(-)	B20	→ Clock(-)		

2 Mechanical Considerations



3 Operating the E5404A-Pro Series Probes

Electrical considerations such as equivalent probe loads, input impedance, and time domain transmission (TDT).



Equivalent Probe Loads

The following probe load models are based on in-circuit measurements made with an Agilent 8753E 6 GHz network analyzer and an Agilent 54750A TDR/TDT using a 50 Ω test fixture. The following schematic accurately models the probe load out to 6 GHz. The figure on the following page shows the agreement between measured impedance and this model.

Simple

(Does not include capacitive coupling between channels or inductance of the spring pins)

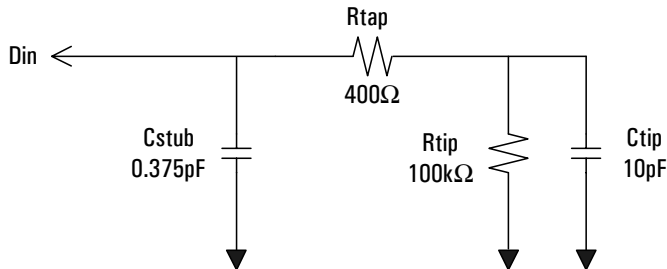

Complex

(Includes capacitive coupling between channels and inductance of spring pins.)

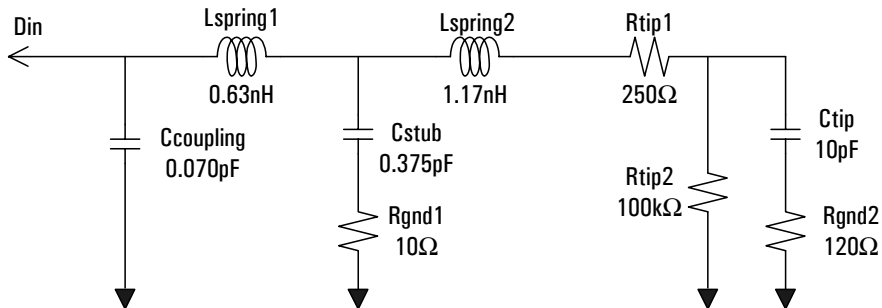

Figure 21 Probe load models (E5404A)

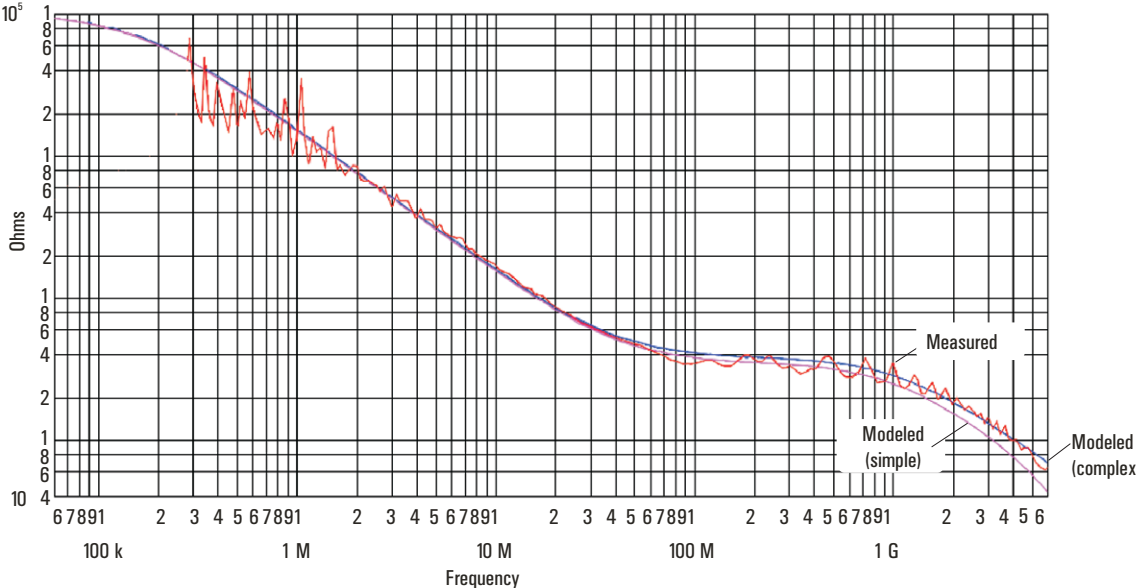

Figure 22 Measured versus modeled input impedance (E5404A)

Time Domain Transmission (TDT)

All probes have a loading effect on the circuit when they come in contact with the circuit. Time domain transmission (TDT) measurements are useful for understanding the probe loading effects as seen at the target receiver. The following TDT measurements were made mid-bus on a 50Ω transmission line load terminated at the receiver. These measurements show how the soft touch probes affect an ideal step seen by the receiver for various rise times.

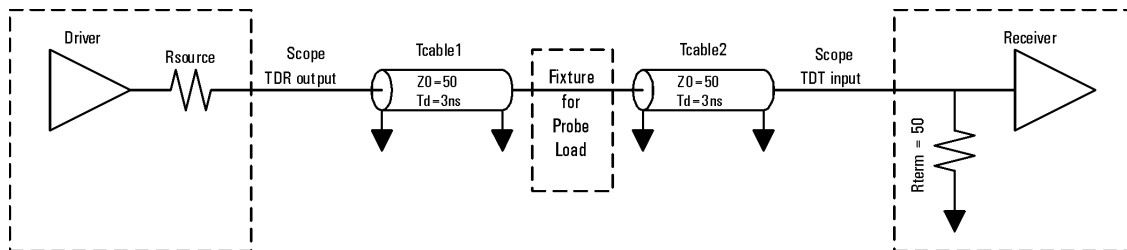

Figure 23 TDT measurement schematic (E5404A)

The following plots were made on an Agilent 54750A oscilloscope using TDT.

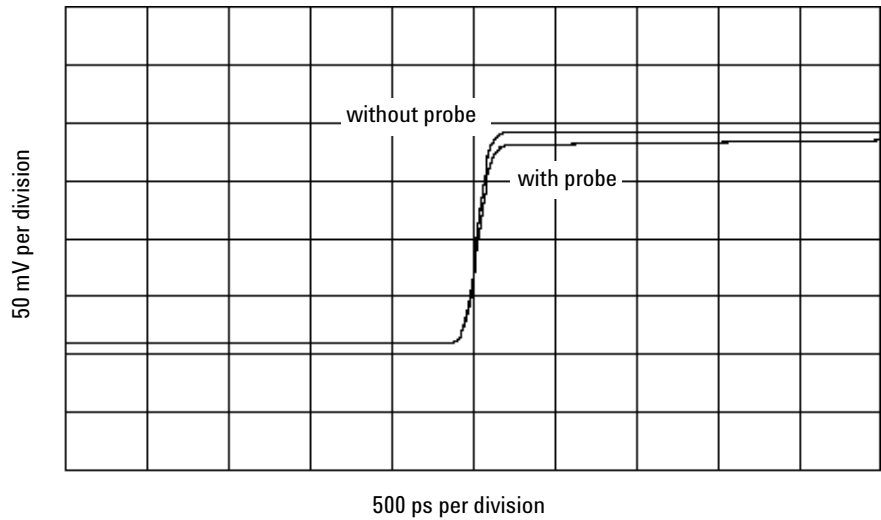

Figure 24 TDT measurement at receiver with and without probe load for 150 ps rise time

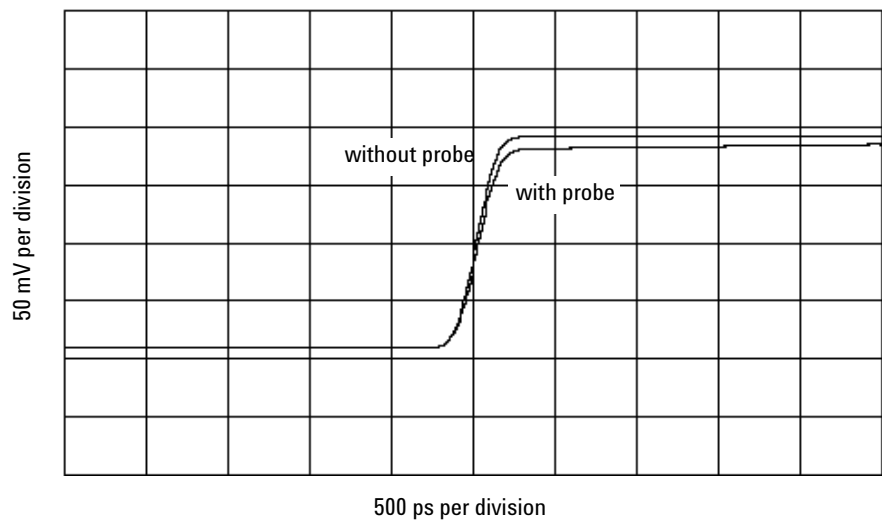

Figure 25 TDT measurement at receiver with and without probe load for 250 ps rise time

3 Operating the E5404A-Pro Series Probes

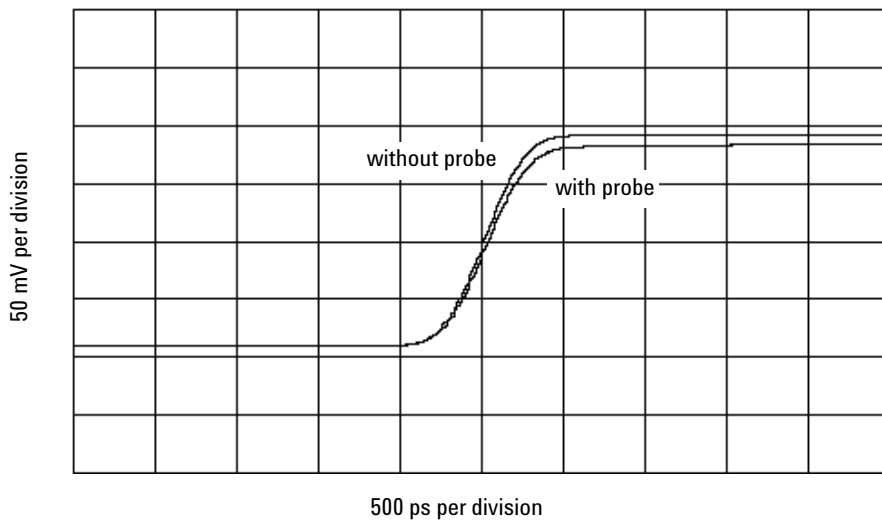

Figure 26 TDT measurement at receiver with and without probe load for 500 ps rise time

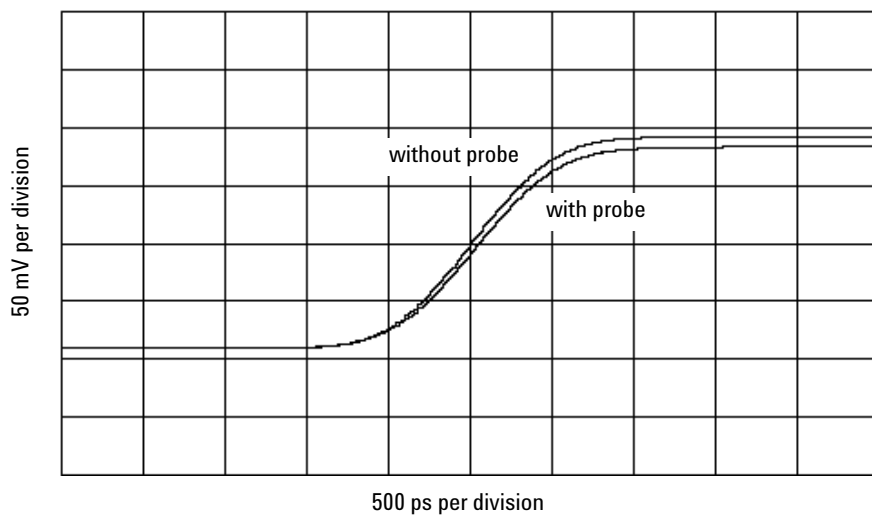

Figure 27 TDT measurement at receiver with and without probe load for 1000 ps rise time



4

Operating the E5402A, E5405A and E5406A-Pro Series Probes

Electrical considerations such as equivalent probe loads, input impedance, time domain transmission (TDT), step inputs, and eye opening.



Equivalent Probe Loads

The following probe load models are based on in-circuit measurements made with an Agilent 8753E 6 GHz network analyzer and an Agilent 54750A TDR/TDT using a 50 Ω test fixture. The following schematic accurately models the probe load out to 6 GHz. The figure on the following page shows the agreement between measured impedance and this model. PCB board pads are not included.

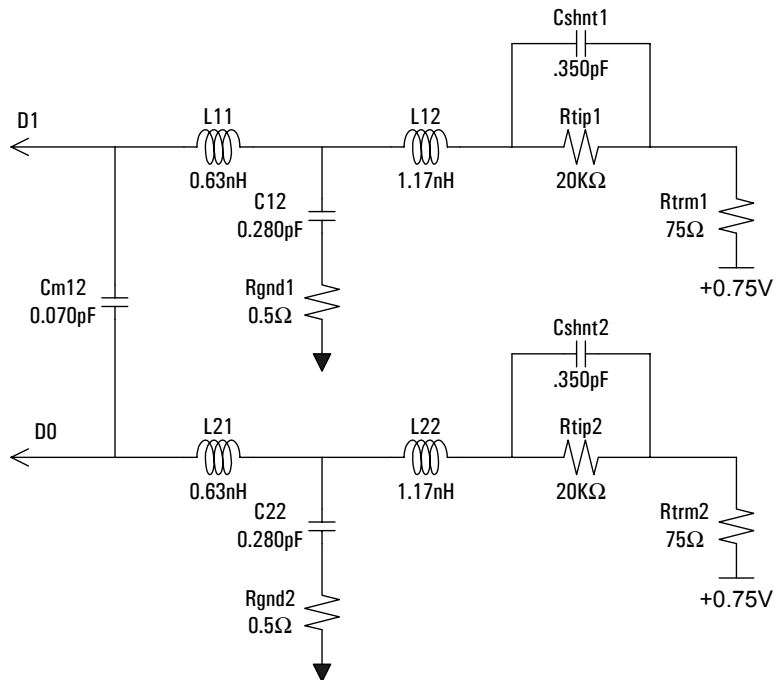

Figure 28 Probe load model (E5402A, E5405A and E5406A)

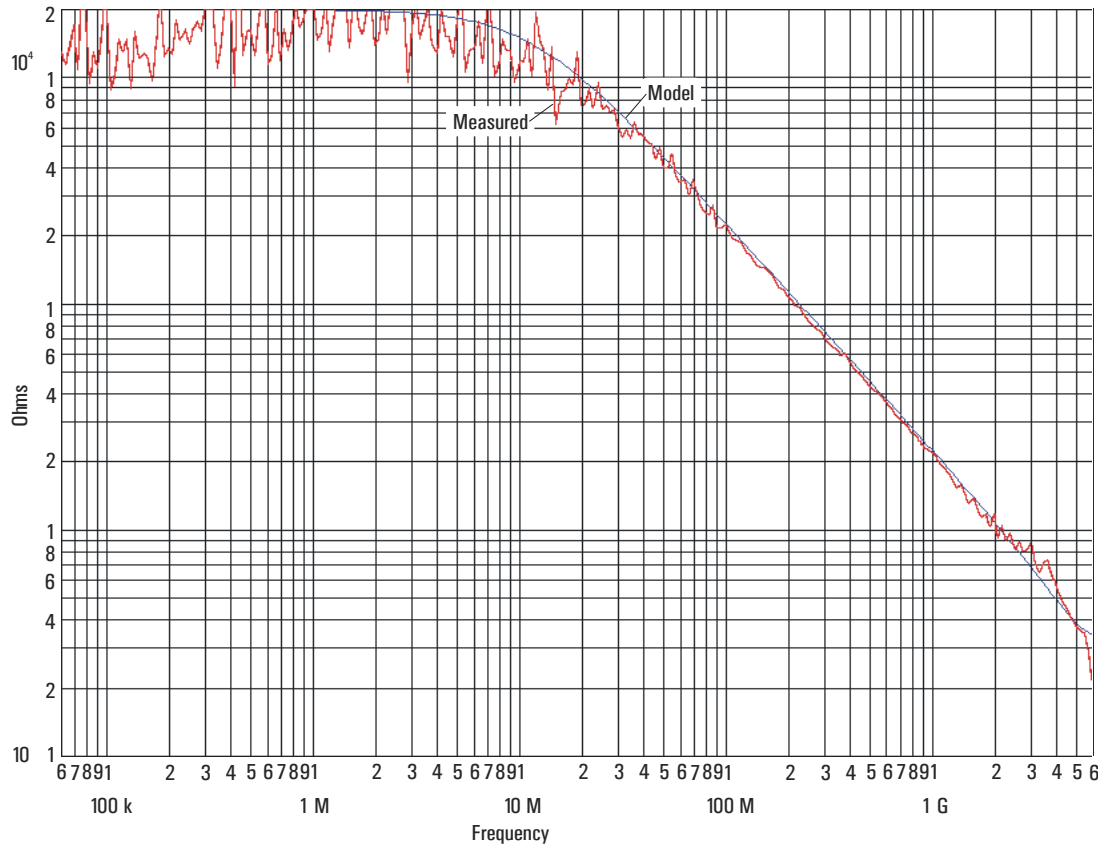

Figure 29 Measured versus modeled input impedance (E5402A, E5404A and E5406A)

Time Domain Transmission (TDT)

All probes have a loading effect on the circuit when they come in contact with the circuit. Time domain transmission (TDT) measurements are useful for understanding the probe loading effects as seen at the target receiver. The following TDT measurements were made mid-bus on a 50Ω transmission line load terminated at the receiver. These measurements show how the E5402A, E5405A, and E5406A-pro series soft touch probes affect an ideal step seen by the receiver for various rise times.

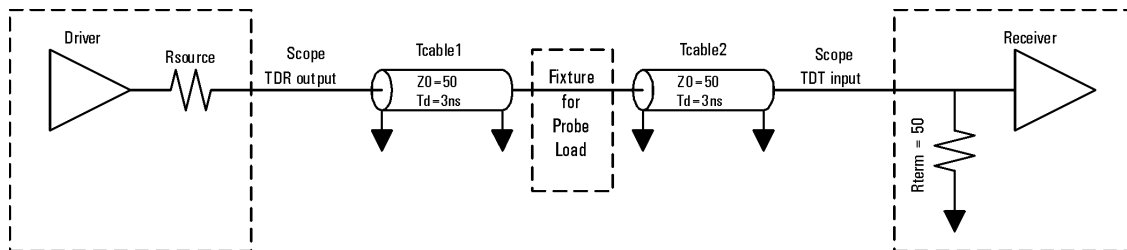

Figure 30 TDT measurement schematic (E5402A, E5405A and E5406A)

The following plots were made on an Agilent 54750A oscilloscope using TDT.

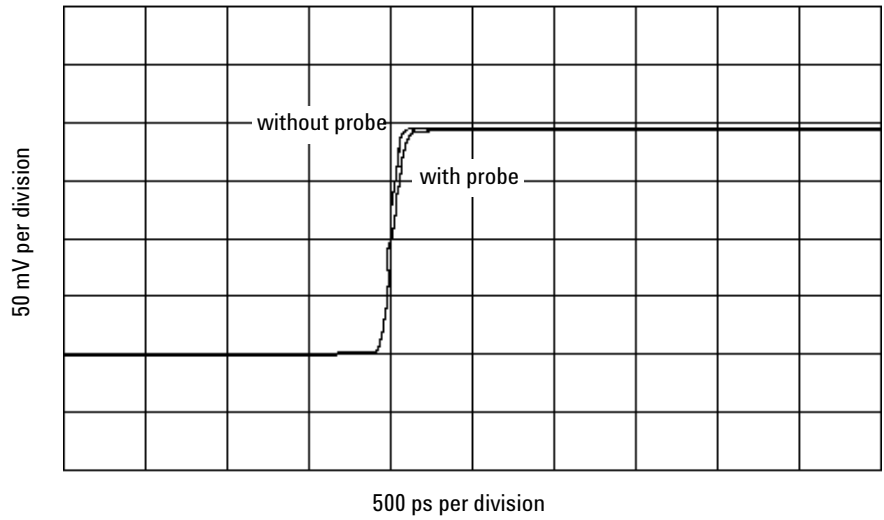

Figure 31 TDT measurement at receiver with and without probe load for 100 ps rise time

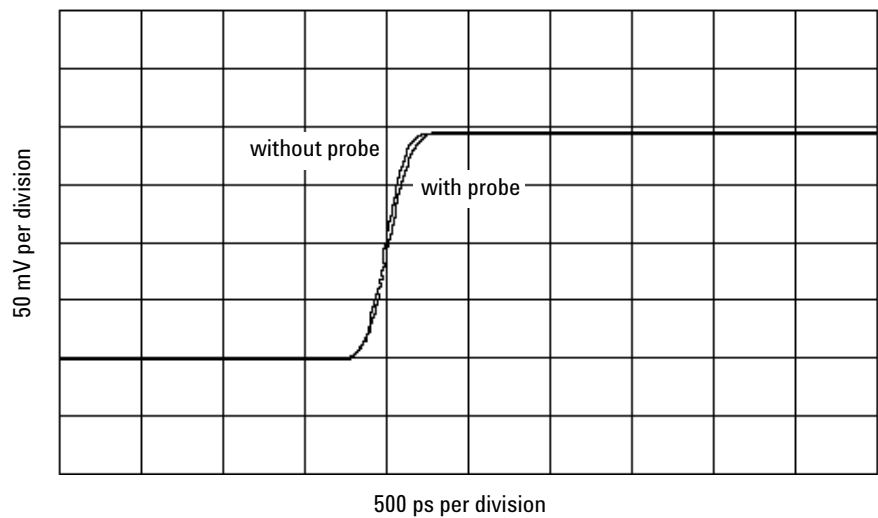

Figure 32 TDT measurement at receiver with and without probe load for 250 ps rise time

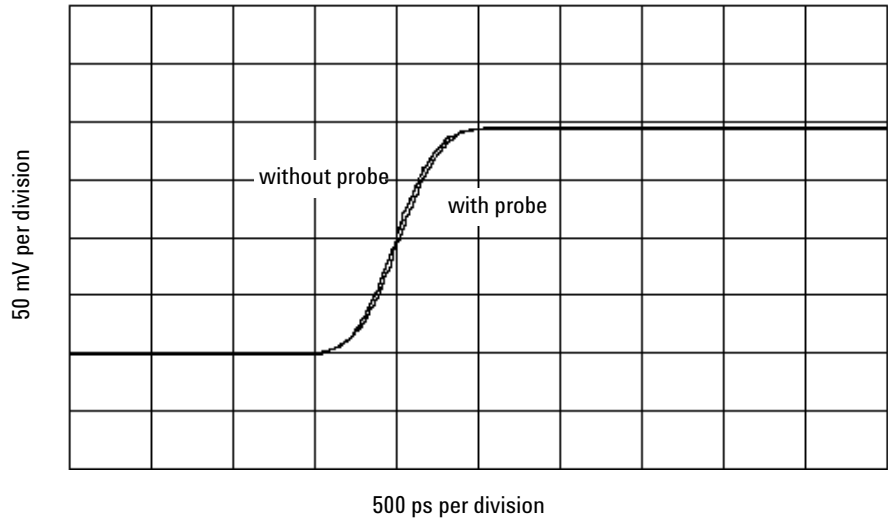

Figure 33 TDT measurement at receiver with and without probe load for 500 ps rise time

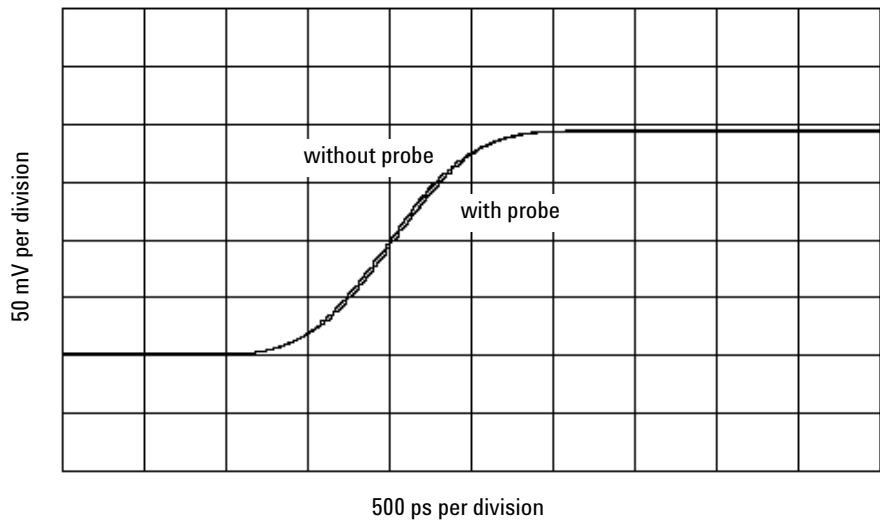

Figure 34 TDT measurement at receiver with and without probe load for 1000 ps rise time

Step Inputs

Maintaining signal fidelity to the logic analyzer is critical if the analyzer is to accurately capture data. One measure of a system's signal fidelity is to compare V_{in} to V_{out} for various step inputs. For the following graphs, V_{in} is the signal at the logic analyzer probe tip. Eye Scan was used to measure V_{out} , the signal seen by the logic analyzer. The measurements were made on a mid-bus connection to a 50Ω transmission line load terminated at the receiver. These measurements show the logic analyzer's response while using the E5402A, E5405A and E5406A-pro series soft touch probes.

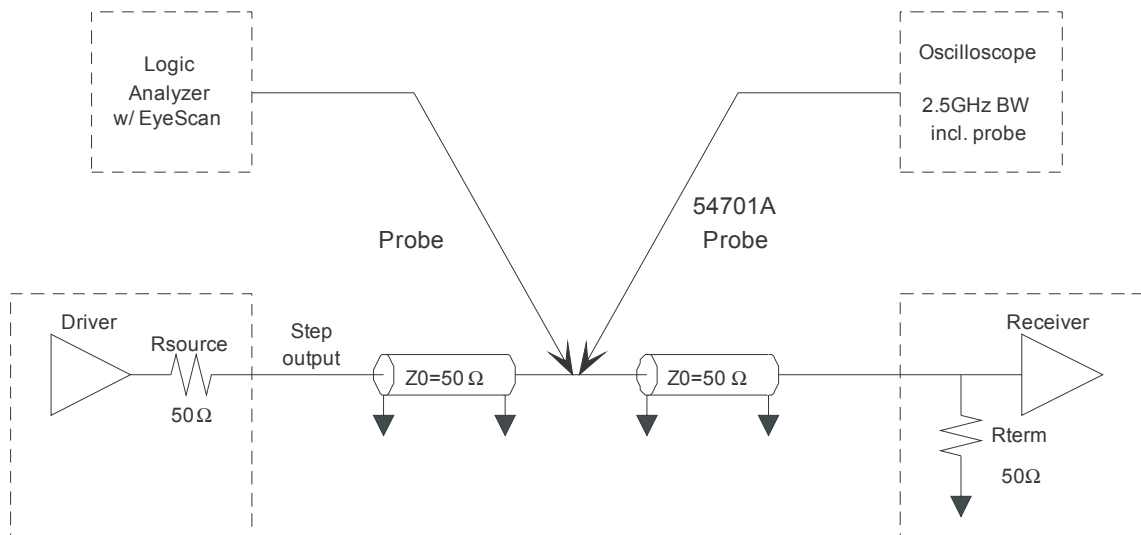

Figure 35 Step input measurement schematic (E5402A, E5405A and E5406A)

The following plots were made on an Agilent 54750A oscilloscope and an Agilent 16760A logic analyzer using an Agilent 8133A pulse generator with various rise time converters.

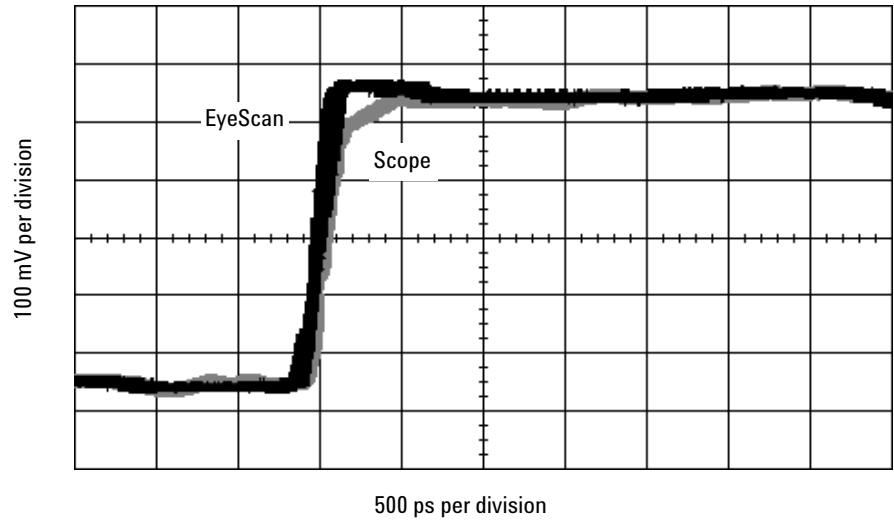

Figure 36 Logic analyzer's response to 150 ps rise time

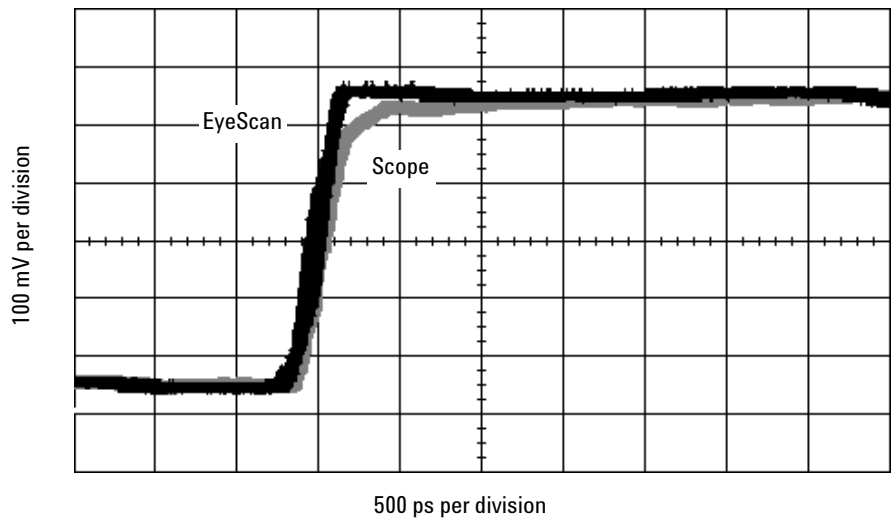

Figure 37 Logic analyzer's response to 250 ps rise time

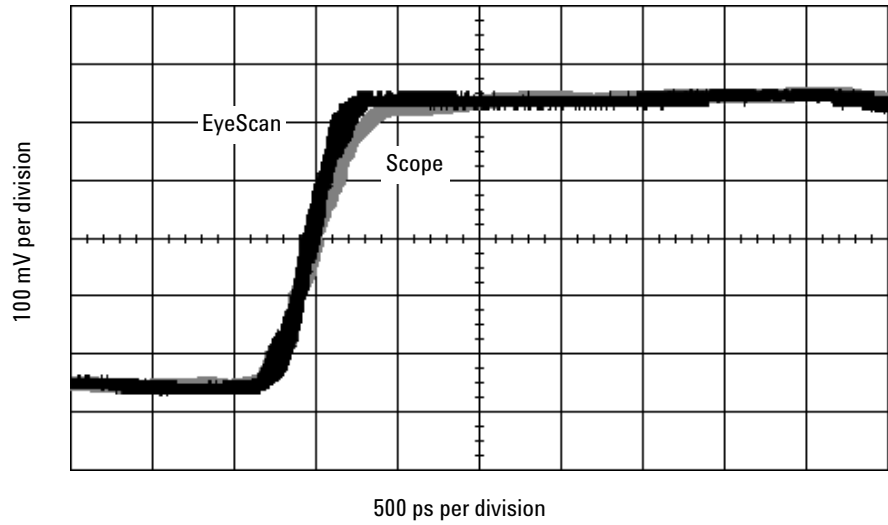

Figure 38 Logic analyzer's response to 500 ps rise time

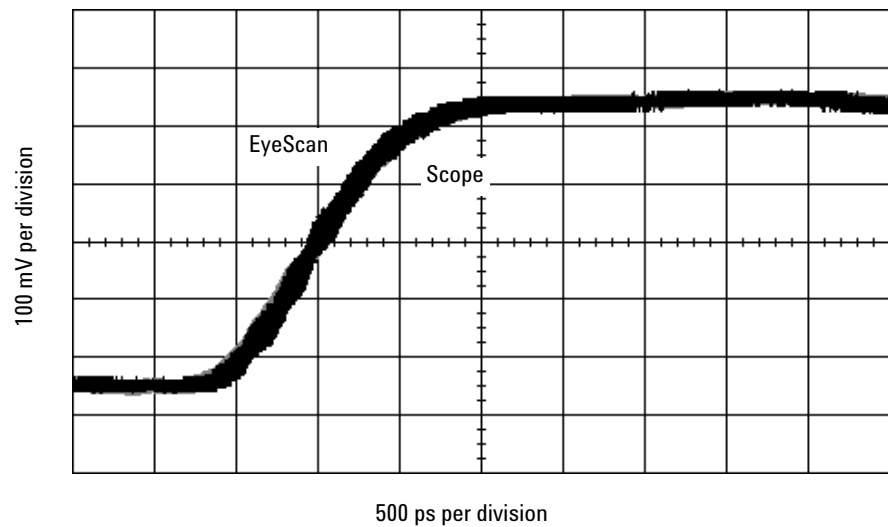

Figure 39 Logic analyzer's response to 1000 ps rise time

Eye Opening

The eye opening at the logic analyzer is the truest measure of an analyzer's ability to accurately capture data. Seeing the eye opening at the logic analyzer is possible with Eye Scan. The eye opening viewed with Eye Scan helps the user know how much margin the logic analyzer has, where to sample and at what threshold. Any probe response that exhibits overshoot, ringing, probe non-flatness, noise, and other issues all deteriorate the eye opening seen by the logic analyzer. The following eye diagrams were measured using E5402A, E5405A and E5406A-pro series soft touch probes and Eye Scan while probed mid-bus on a 50Ω transmission line load terminated at the receiver. The data patterns were generated using a $2^{23}-1$ pseudo random bit sequence (PRBS).

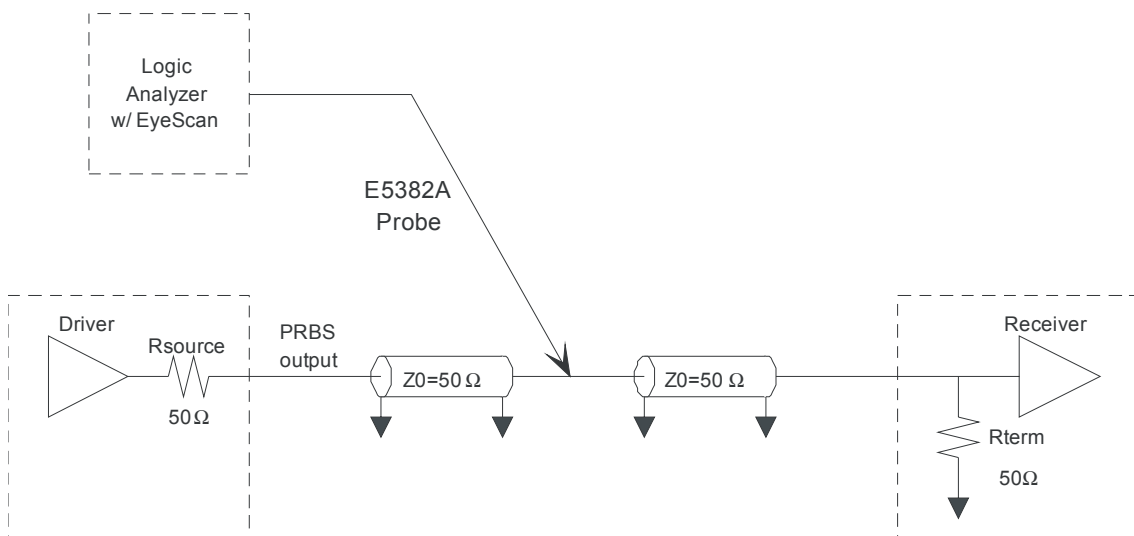

Figure 40 Eye opening measurement schematic (E5402/05/06A)

The following plots were made on an Agilent 16760A logic analyzer using an Agilent 8133A pulse generator with a 250 ps rise time converter. The following measurements use Eye Scan to show the margin at 800, 1250, and 1500MT/s. The amplitudes are indicated in the captions.

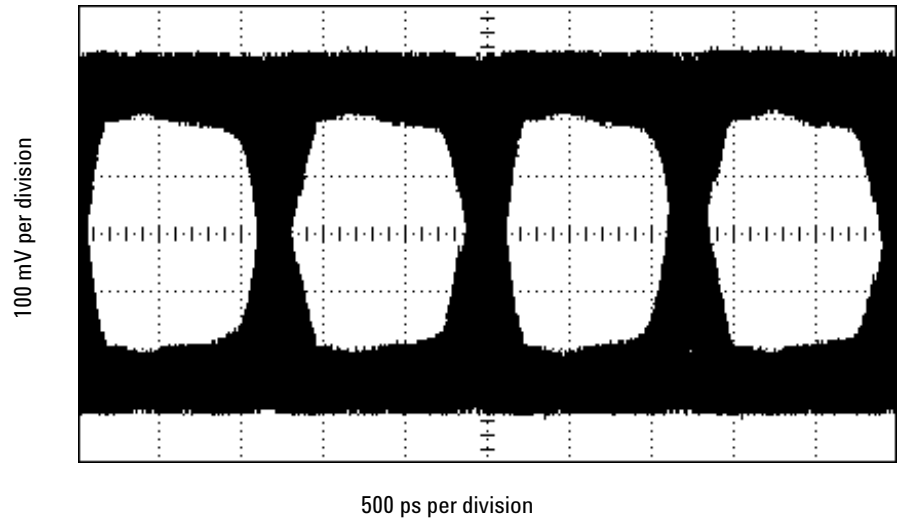

Figure 41 Logic analyzer eye opening for a PRBS signal of 500 mV p-p, 800 MT/s data rate

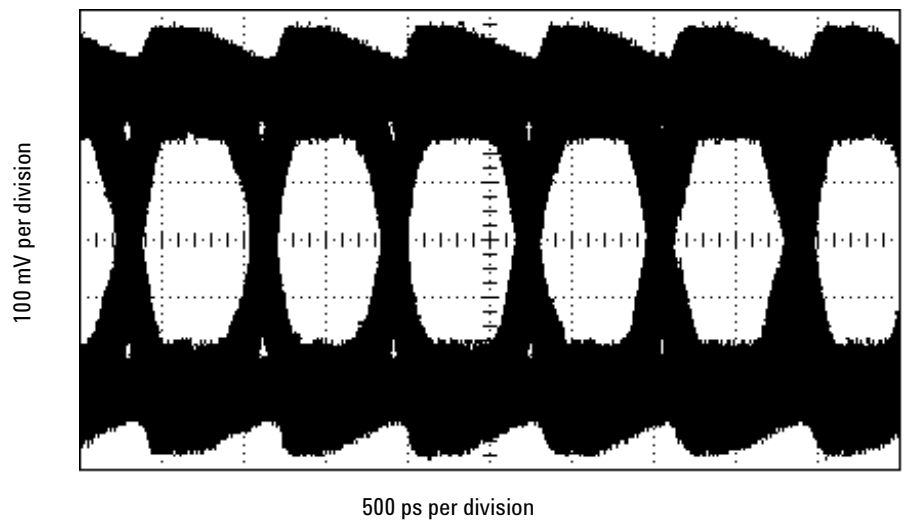

Figure 42 Logic analyzer eye opening for a PRBS signal of 500 mV p-p, 1250 MT/s data rate

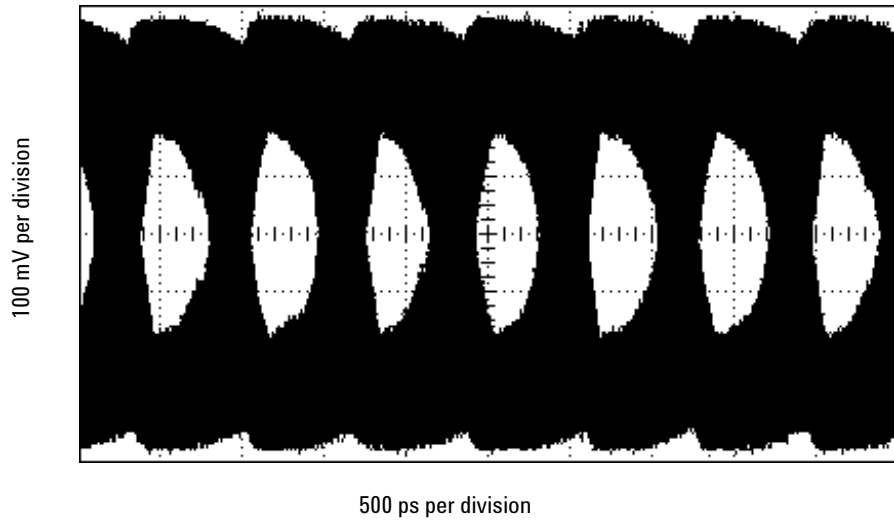

Figure 43 Logic analyzer eye opening for a PRBS signal of 500 mV p-p, 1500 MT/s data rate

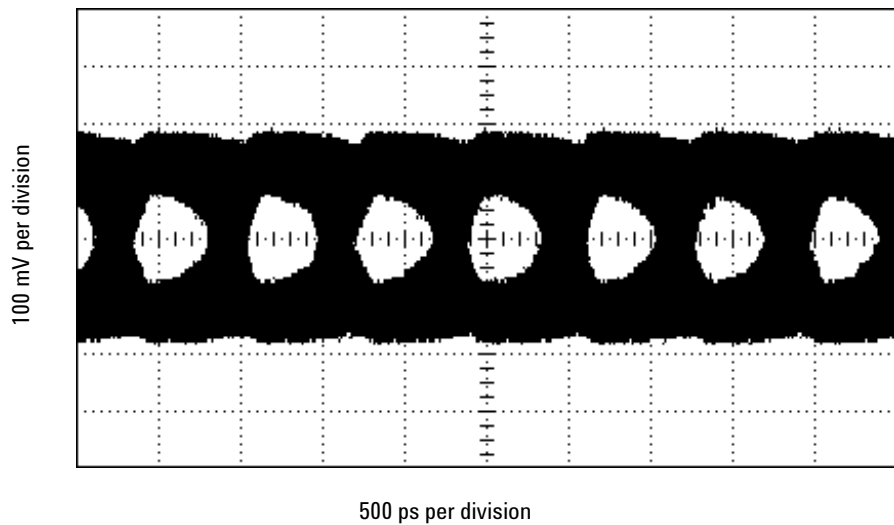

Figure 44 Logic analyzer eye opening for a PRBS signal of 200 mV p-p, 1500 MT/s data rate



5 Circuit Board Design

Design considerations when you layout your circuit board.



Transmission Line Considerations

Stubs connecting signal transmission lines to the connector should be as short as feasible. Longer stubs will cause more loading and reflections on a transmission line. If the electrical length of a stub is less than $1/5$ of the signal rise time, it can be modeled as a lumped capacitance. Longer stubs must be treated as transmission lines.

Example: Assume you are using FR-4 PC board material with a dielectric constant of ~ 4.3 for inner-layer traces (stripline). For example, A 0.28 cm long stub in an inner layer has a propagation delay of ~ 20 ps. Therefore, for a signal with a rise time of 100 ps or greater, a 0.28 cm stub will behave like a capacitor.

The trace capacitance per unit length will depend on the trace width and the spacing to ground or power planes. If the trace is laid out to have a characteristic impedance of 50Ω it turns out that the capacitance per unit length is ~ 1.2 pF/cm. Therefore the 0.28 cm stub in the previous example would have an effective capacitance equal to ~ 0.34 pF.

This trace capacitance is in addition to the probe load model.

Recommended Routing

Two rows of compliant contacts in the probe make contact with pads laid down on the surface of the PC board. These contacts provide an extremely low probe load (<0.70 pF per channel), and make a good electrical connection with a small amount of compression force on a choice of standard PCB platings. Additionally, the pin contact points are free from the contamination effects that plague other connector-less probing technologies.

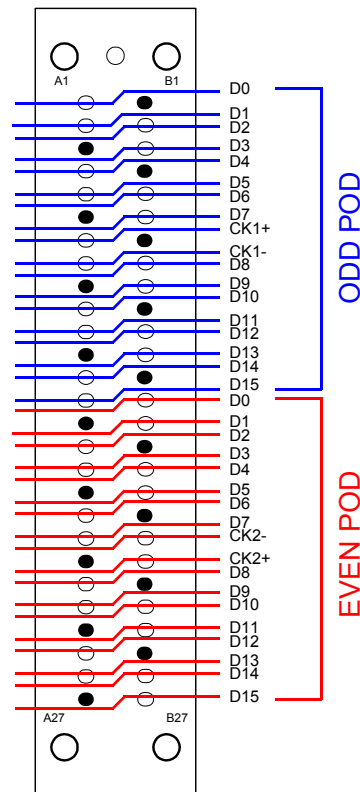

Figure 45 34-bit single-ended routing (E5402A, E5404A and E5406A)

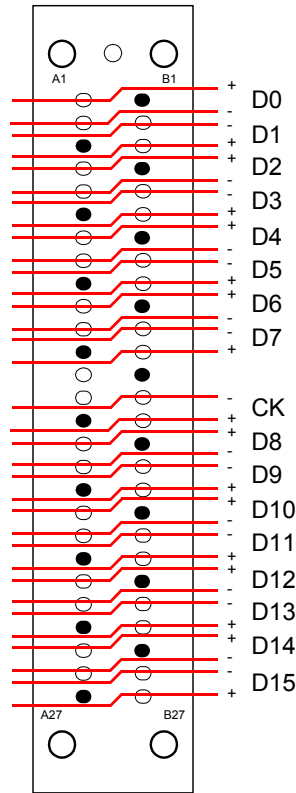

Figure 46 17-bit differential routing (E5405A)

Data and Clock Inputs per Operating Mode

The following table shows the number of data and clock inputs for each connector on your target system for the various operating modes of your logic analyzer.

Table 6 16760A logic analyzer

Operating Mode	E5405A 17-channel differential soft touch	E5405A with half-channel adapter E5386A	E5402A or E5406A 34-channel single-ended soft touch	E5402A or E5406A with half-channel adapter E5386A
Synchronous (state) analysis 200 Mb/s, 400 Mb/s, 800 Mb/s	16 data plus 1 clock input (see note 1)	N/A	32 data plus 2 clock inputs (see note 1)	N/A
Synchronous (state) analysis 1250 Mb/s 1500 Mb/s	8 data plus 1 clock input (see note 2)	16 data plus 1 clock input (see note 2)	16 data plus 1 clock input (see note 2)	16 data plus 1 clock input (see note 2)
Eye scan mode 800 Mb/s	16 data plus 1 clock input (see note 1)	N/A	32 data plus 2 clock inputs (see note 1)	N/A
Eye scan mode 1500 Mb/s	8 data plus 1 clock input (see note 2)	16 data plus 1 clock input (see note 2)	16 data plus 1 clock input (see note 2)	16 data plus 1 clock input (see note 2)
Timing mode	16 data plus 1 clock input (see note 3)	N/A	32 data plus 2 clock inputs (see note 3)	N/A

Note 1: In the 200 Mb/s, 400 Mb/s, and 800 Mb/s synchronous (state) analysis modes, and the 800 Mb/s eye scan mode, there is one clock input which must be routed to the clock input on pod 1 (of the master module, in a multi-card set). The clock inputs on other pods can be assigned to labels and acquired as data inputs.

Note 2: In the 1250 Mb/s and 1500 Mb/s synchronous (state) analysis modes, and in the 1500 Mb/s eye scan mode, the clock inputs on other pods cannot be assigned to labels and acquired as data inputs.

Note 3: In asynchronous (timing) analysis, all inputs including clocks can be acquired and assigned to labels.

- To realize 17 data inputs (in full-channel mode) while using time tags in addition to a clock input on a single 16760A module or on the master module in a multi-card set, you must route the data signals to pod 2 and the clock to pod 1. A convenient way to avoid laying out a second connector to connect only the clock signal is to use the Agilent E5382A flying-lead set to make the connection to the clock.
- To use the qualifier input for eye scan, the qualifier signal must be routed to the clock input on pod 2 (K clock), and the clock must be routed to the clock input on pod 1 (J clock), each on the master module in case of a multi-card set.
- In a multiple-card set, the clock used for synchronous (state) analysis must be routed to the clock input on pod 1 of the master module. On a single card, the clock must be routed to the clock input on pod 1.

Table 7 16753/54/55/56A and 16950A logic analyzers

Operating Mode	E5405A 17-channel differential soft touch	E5402A or E5406A 34-channel single-ended soft touch
Synchronous (state) analysis 300 Mb/s 800 Mb/s,	16 data plus 1 clock input (see note 1)	32 data plus 2 clock inputs (see note 1)
Eye scan mode 300 Mb/s 600 Mb/s	16 data plus 1 clock input (see note 1)	32 data plus 2 clock inputs (see note 1)
Timing mode	16 data plus 1 clock input (see note 1)	32 data plus 2 clock inputs (see note 3)

Note 1: In 600 Mb/s mode, there is one clock input which must be routed to the clock input on pod 1 of the master module in a multi-card set. The clock inputs on the other pods can be assigned to labels and acquired as data inputs.

Table 8 1670 Series, 1680/90 Series, 16710/11/12A, 16715/16/17A, 16740/41/4A, 16750/51/52B, 16910/11A logic analyzers

Operating Mode	E5404A 34-channel single-ended soft touch
Synchronous (state) analysis 250 Mb/s, 500 Mb/s,	32 data plus 2 clock inputs (see note 1)
Timing mode	32 data plus 2 clock inputs (see note 1)

Note 1: In 500 Mb/s mode, there is one clock input which must be routed to the clock input on pod 1 of the master module in a multi-card set. The clock inputs on the other pods can be assigned to labels and acquired as data inputs.

Thresholds

E5404A-pro series single-ended soft touch probes

Data inputs

The threshold can be changed on a “per pod” basis (16 data + 1 clock). This is accomplished using the “user defined threshold” window in the logic analyzer software.

E5405A-pro series differential soft touch probe

Data inputs

If you are using the E5405A differential soft touch probe to acquire differential signals, you would normally allow the logic analyzer to discriminate between high and low states based on the crossover of the data and $\overline{\text{data}}$ inputs.

You may also use the E5405A differential probe to acquire single-ended signals. If you are using the E5405A probe to $\overline{\text{data}}$ acquire single-ended signals, you should either ground the $\overline{\text{data}}$ inputs or connect them to a dc power supply. You may:

- Ground the $\overline{\text{data}}$ inputs and adjust the threshold in the user interface.

Or

- Supply a threshold reference voltage to the $\overline{\text{data}}$ inputs. In this case, the threshold in the user interface should be set to zero.

If your circuit uses a resistive divider to provide a threshold reference, make sure the thevenin equivalent resistance is around 50 Ω .

NOTE

The data thresholds can only be changed on a 16-bit per pod basis (16 data). All clock thresholds can be changed individually.

Clock input

The same choices exist for the clock input on the E5405A differential probe as outlined above for the data inputs. The clock input has a separate, independent threshold adjustment.

E5402A and E5406A-pro series single-ended soft touch probes

Clock input

The clock input to the E5402A and E5406A probe is differential. If you supply a differential clock, you should select the "differential" option in the clock threshold user interface.

If your system uses a single-ended clock signal, the $\overline{\text{clock}}$ input should be either grounded or connected to a dc power supply. You may:

- Ground the $\overline{\text{clock}}$ input and adjust the clock threshold from the user interface to between -3V dc and +5V dc.

Signal Access

Labels split across probes

If a label is split across more than one pod, this leads to restrictions in triggering. Refer to "Triggering with the Agilent 1675x and 1676x" (Agilent publication number 5988-2994EN) for more details.

Reordered bits

If bits need to be reordered within a label, this leads to additional restrictions in triggering. Specifically, equalities can be used to evaluate the value of a label with reordered bits, but inequalities cannot be used. You may be able to avoid the need to reorder bits in a label by routing signals to appropriate pins on the probe connector. Refer to "Triggering with the Agilent 1675x and 1676x" (Agilent publication number 5988-2994EN) for more details.

Half-channel 1.25 and 1.5 Gb/s modes (16760A only)

In the half-channel 1.25 and 1.5 Gb/s modes, the 16760A analyzer accesses only the even channels (0,2,4, etc.). In the Format user interface, only the even data bits will be connected to the analyzer.

Note that in the 1.25 and 1.5 Gb/s half-channel mode, the clock inputs cannot be assigned as bits in a label.

E5386A Half-channel Adapter The E5386A can be used with the E5405A-pro series differential soft touch probe or the E5402A/E5406A-pro series single-ended probes to map the signals from the PC board pads to the 16760A when operating in half-channel state mode.

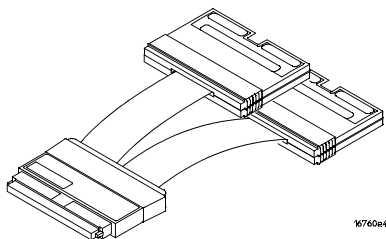

Figure 47 E5386A Half-channed adapter



6 Recommended Reading

A list of recommended reading for more information about systems and high-speed digital design.



For More Information

For more information on Agilent logic analyzers, refer to <http://www.agilent.com/find/logicanalyzer>. For more information on your specific analyzer, refer to the online help in the product.

For information on other Agilent probing solutions, refer to http://www.agilent.com/find/logic_analyzer_probes.

MECL System Design Handbook

Blood, William R. Jr., "MECL System Design Handbook," 4th edition, 1988, published by Motorola. This handbook can be obtained from ON Semiconductor on the web. Go to <<http://onsemi.com>>. Click on "On-line ordering" under "Documentation." Click on the link "General search." Type in "HB205" in the "Document number" field. Click "Submit." To view the document online, click on "PDF" in the right-hand column titled "PDF MFAX." Or order a hardcopy of the handbook on-line.

High-speed Digital Design

Johnson, Howard W., and Martin Graham, "High-speed Digital Design," Prentice-Hall, 1993, ISBN 0-13-395724-1

Designing High-speed Target Systems for Logic Analyzer Probing

"Designing High-speed Target Systems for Logic Analyzer Probing" Agilent Technologies application note publication number 5988-2989EN.

Safety Notices

This apparatus has been designed and tested in accordance with IEC Publication 1010, Safety Requirements for Measuring Apparatus, and has been supplied in a safe condition. This is a Safety Class I instrument (provided with terminal for protective earthing). Before applying power, verify that the correct safety precautions are taken (see the following warnings). In addition, note the external markings on the instrument that are described under "Safety Symbols."

Warnings

- Before turning on the instrument, you must connect the protective earth terminal of the instrument to the protective conductor of the (mains) power cord. The mains plug shall only be inserted in a socket outlet provided with a protective earth contact. You must not negate the protective action by using an extension cord (power cable) without a protective conductor (grounding). Grounding one conductor of a two-conductor outlet is not sufficient protection.
- Only fuses with the required rated current, voltage, and specified type (normal blow, time delay, etc.) should be used. Do not use repaired fuses or short-circuited fuseholders. To do so could cause a shock or fire hazard.
- If you energize this instrument by an auto transformer (for voltage reduction or mains isolation), the common terminal must be connected to the earth terminal of the power source.
- Whenever it is likely that the ground protection is impaired, you must make the instrument inoperative and secure it against any unintended operation.
- Service instructions are for trained service personnel. To avoid dangerous electric shock, do not perform any service unless qualified to do so. Do not attempt internal service or adjustment unless another person, capable of rendering first aid and resuscitation, is present.
- Do not install substitute parts or perform any unauthorized modification to the instrument.
- Capacitors inside the instrument may retain a charge even if the instrument is disconnected from its source of supply.
- Do not operate the instrument in the presence of flammable gases or fumes. Operation of any electrical instrument in such an environment constitutes a definite safety hazard.
- Do not use the instrument in a manner not specified by the manufacturer.

To clean the instrument

If the instrument requires cleaning: (1) Remove power from the instrument. (2) Clean the external surfaces of the instrument with a soft cloth dampened with a mixture of mild detergent and water. (3) Make sure that the instrument is completely dry before reconnecting it to a power source.

Safety Symbols



Instruction manual symbol: the product is marked with this symbol when it is necessary for you to refer to the instruction manual in order to protect against damage to the product..



Hazardous voltage symbol.



Earth terminal symbol: Used to indicate a circuit common connected to grounded chassis.

Index

A

- adapter, E5386A half-channel, [18](#)
- Agilent web site
 - logic analyzer info, [70](#)
 - probing, [70](#)
 - soft touch probes, [13](#)
- amplitude, [16](#)
- analyzer, [70](#)
- at a glance, [8](#)
- attach retention module, [10](#)

B

- bottom-side attach, [11](#)

C

- Characteristics, [20](#)
- circuit board design, [59](#)
- cleaning the instrument, [71](#)
- clock inputs, [63](#)
 - E5405A, [66](#)
 - E5406A, [67](#)

D

- data inputs, [63](#)
 - E5404A, [66](#)
 - E5405A, [66](#)
 - E5406A, [67](#)
- definition
 - differential input, [16](#)
- design
 - for logic analyzer probing, [70](#)
 - high-speed digital, [70](#)
 - high-speed target systems, [70](#)
 - MECL, [70](#)
- design theory, [59](#)
- differential
 - input amplitude, [16](#)

- differential probe
 - E5405A, [16](#)
- dimensions
 - E5386A half-channel adapter, [36](#)
 - E5404A probe, [21](#)
 - E5405A probe, [23](#)
 - E5406A probe, [24](#)
 - footprint, [27](#)
 - retention module, [25](#)

E

- E5386A half-channel adapter, [18](#)
- E5404A 34-chan single ended, [14, 15](#)
- E5405A 17-chan differential, [16](#)
- E5406A 34-chan single-ended, [17](#)
- equivalent probe loads
 - E5404A, [42](#)
 - E5405A, [48](#)
 - E5406A, [48](#)
- eye opening, [56](#)
- eye scan, [63](#)

F

- footprint dimensions, [27](#)

H

- half-channel adapter, [18](#)
- half-channel mode, [68](#)
- high-speed
 - digital design, [70](#)
 - target system design, [70](#)

I

- input amplitude, [16](#)
- installation, [10](#)
- instrument, cleaning the, [71](#)

K

- keep-out area, [27](#)
- keying pin, [11](#)

L

- labels, [67](#)
- logic analyzer, [70](#)
 - design for probing, [70](#)

M

- MECL system design, [70](#)

N

- Notices, [71](#)
- number of probes required, [12](#)

O

- operating mode, [63](#)
- ordering retention modules, [13](#)
- overview, [8](#)

P

- pinout, [28](#)
 - E5386A used with E5387A, [37](#)
 - E5386A used with E5390A, [38](#)
- probe
 - E5404A single-ended, [14, 15](#)
 - E5405A 17-chan differential, [16](#)
 - E5406A 34-chan single-ended, [17](#)
 - number required, [12](#)
 - state speed, [13](#)
- probe load
 - E5404A, [42](#)
 - E5405A, [48](#)
 - E5406A, [48](#)
- probing options, [12](#)

Index

R

- reordered bits, 67
- replaceable part
 - retention module, 13
- required number of probes, 12
- retention module
 - attaching, 10
 - dimensions, 25
 - ordering, 13
- routing, 61

S

- safety symbols, 72
- selecting a probe, 12
- signal access, 67
- single-ended probe
 - E5405A, 14, 15
 - E5406A, 17
- solder retention module, 10
- state speed, 13
- step inputs, 53
- synchronous state analysis, 63

T

- thresholds, 66
- time domain transmission, 50
 - E5404A, 44
- top-side attach, 10
- transmission line considerations, 60
- triggering, 67